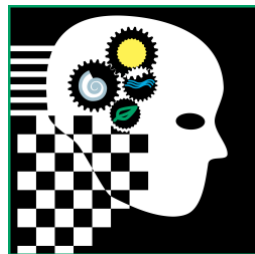


# 2025 Regulations

Release C  
March 27, 2025



Organized by Innovators Educational Foundation

## Contents

<b>SECTION 1 - ADMINISTRATION</b> .....	<b>8</b>
<b>1. Purpose</b> .....	<b>9</b>
1.1 Fundamental Vision .....	9
1.2 Missions .....	9
<b>2. Administration</b> .....	<b>9</b>
2.1 Organizers.....	9
2.1.A Organizers .....	9
2.1.B International Solarcar Federation .....	9
2.2 Event Website .....	9
2.3 Headquarters .....	9
2.4 Officials .....	9
2.4.A Event Director .....	9
2.4.B Regulations Manager.....	9
2.4.C Chief Inspector.....	9
2.4.D Head Timekeeper .....	10
2.4.E Technical, Safety and Fairness Officials .....	10
2.4.F Jury .....	10
2.5 Application of Regulations .....	10
2.6 Supplemental Documents.....	10
2.6.A Additional Documents.....	10
2.6.B Conflict.....	10
2.7 Acceptance of Regulations .....	10
2.8 Event Cancellation .....	10
2.9 Interpretation of Regulations.....	11
2.9.A Interpretation.....	11
2.9.B Official / Unofficial Interpretations.....	11
2.9.C Prior to Scrutineering.....	11
2.9.D During and after Scrutineering.....	11
2.10 Advertising, Promotion, and Publicity .....	11
<b>3. Safety</b> .....	<b>12</b>
3.1 Team Safety.....	12
3.1.A Team Safety Officer.....	12
3.1.B Team Safety Kit .....	12
<b>4. Entries</b> .....	<b>13</b>
4.1 Event Registration.....	13
4.1.A Registration - Initial Registration Package .....	13
4.1.B Registration – Track Registration Package .....	13
4.1.C Grants .....	13
4.1.D Donations.....	13
4.1.E Team Members.....	13
4.1.F Supporters and Additional Team Members.....	13
4.2 Team Data .....	14
4.2.A Team Photo .....	14
4.2.B Data Sheets .....	14
4.3 Registration Deadlines.....	14
4.3.A Registration Dates .....	14
4.3.B Late Penalties .....	14
4.3.C Entry Fee Payments .....	15
4.4 University/College Advisor .....	15
4.4.A University/College Advisor.....	15
4.5 Event Correspondence .....	15
4.5.A Primary Team Contacts .....	15
4.5.B Emails .....	15
4.6 Insurance .....	15
4.7 Withdrawals and Exclusion .....	16
4.7.A Voluntary.....	16
4.7.B Not Meeting Requirements.....	16

4.7.C	Exclusion.....	16
4.8	Team Numbers: .....	16
4.9	Participant Registration.....	16
<b>5.</b>	<b>Technical Documentation.....</b>	<b>17</b>
5.1	Preliminary Vehicle Design Report (PVDR) .....	17
5.1.A	PVDR Contents .....	17
5.2	Vehicle Design Report (VDR) .....	17
5.2.A	Document Format.....	17
5.2.B	Mechanical Technical Report .....	17
5.2.C	Electrical System Technical Report.....	18
5.2.D	Battery Tech Report.....	18
5.2.E	Battery Protection Tech Report: .....	19
5.2.F	Solar Cell Tech Report .....	19
5.3	Grading of Team Reports .....	19
5.4	Build Review .....	19
<b>6.</b>	<b>Event Components.....</b>	<b>20</b>
6.1	Scrutineering.....	20
6.1.A	Acceptance at Scrutineering.....	20
6.1.B	Participation at Scrutineering.....	20
6.1.C	Scrutineering Time and Location.....	20
6.1.D	Scrutineering Format .....	20
6.1.E	Configuration and Drivers for Scrutineering .....	20
6.2	The Track Event.....	20
6.2.A	Participation at the Track Event.....	20
6.2.B	Acceptance at the Track Event.....	20
<b>7.</b>	<b>Vehicle Classes .....</b>	<b>21</b>
7.1	Vehicle Class Definitions .....	21
7.1.A	Single-Occupant (SOV) .....	21
7.1.B	Multi-Occupant (MOV) .....	21
7.1.C	Demonstration (DEMO).....	21
<b>SECTION 2 – TECHNICAL .....</b>		<b>22</b>
<b>8.</b>	<b>Power .....</b>	<b>23</b>
8.1	Solar Collector.....	23
8.1.A	Cell Type.....	23
8.1.B	Solar Collector Size Limits.....	23
8.1.C	Definition of Area .....	23
8.1.D	Concentrators .....	23
8.1.E	Maximum Number of Cell Types and Sizes .....	23
8.1.F	Validation Documentation.....	23
8.1.G	Solar Collector Connection and Stands .....	23
8.1.H	Water Spray .....	23
8.1.I	Solar Collector Reconfiguration.....	23
8.1.J	External Irradiance Amplification .....	23
8.2	Energy Storage .....	24
8.2.A	Battery Capacity Limits .....	24
8.2.B	Other Energy Storage Methods.....	24
8.2.C	Supplemental Batteries .....	24
8.2.D	Commercial Batteries .....	24
8.2.E	Other Storage Devices .....	24
8.3	Protection Circuitry.....	25
8.3.A	Definitions .....	25
8.3.B	Types .....	25
8.4	Battery Enclosures .....	26
8.4.A	Isolation.....	26
8.4.B	Mounting .....	26
8.4.C	Marking .....	26
8.4.D	Ventilation .....	26
8.4.E	External Cooling .....	26

8.4.F	Security .....	26
8.5	Fusing .....	27
8.5.A	Main .....	27
8.5.B	Branch.....	27
8.5.C	Voltage Taps.....	27
8.6	Power Switch .....	27
8.6.A	Main Power Switch .....	27
8.6.B	BPS Fault Dash Indication.....	27
8.6.C	External Power Cut Off Switch .....	28
8.7	Cables .....	28
8.7.A	Cable Sizing.....	28
8.8	Control.....	28
8.8.A	Sole Control .....	28
8.8.B	Accelerator.....	28
8.8.C	Cruise Control.....	28
8.8.D	Reverse.....	28
8.9	Electrical Shock Hazards .....	29
8.10	Impound .....	29
8.10.A	Impound Box.....	29
8.10.B	Impound In Vehicle .....	29
8.10.C	Impound Security Seal Marking.....	29
8.11	Multi-Occupant Vehicle Charging and Metering .....	30
8.11.A	Charger .....	30
8.11.B	Vehicle Power Inlet .....	30
8.11.C	Charging Adapter.....	30
8.11.D	Energy Metering .....	30
8.11.E	Charging Safety .....	30
8.11.F	Electric Vehicle Supply Equipment (EVSE).....	31
8.11.G	MOV Impound.....	31
<b>9.</b>	<b>Solar Car Body .....</b>	<b>32</b>
9.1	Solar Car Dimensions .....	32
9.2	Driving Configuration .....	32
9.3	Ground Clearance.....	32
9.4	Lighting.....	32
9.4.A	Daytime Running Lights .....	32
9.4.B	Front Turn Indicators .....	32
9.4.C	Side Marker Turn Indicators .....	32
9.4.D	Rear Brake Lights .....	33
9.4.E	Rear Turn Indicators .....	33
9.4.F	High Mounted Center Brake Light .....	33
9.4.G	BPS Fault Indicator.....	34
9.4.H	Emergency Hazard .....	34
9.4.I	Horn .....	34
9.5	Visibility .....	34
9.5.A	Eye Height .....	34
9.5.B	Forward and Sideward Vision.....	34
9.5.C	Windshield .....	35
9.5.D	Rain Clearing .....	35
9.5.E	Rear Vision .....	35
9.5.F	Outside Air Circulation .....	35
9.6	Egress .....	36
9.6.A	Performance Requirement .....	36
9.6.B	Occupant Cockpit and Opening.....	36
9.7	Ballast .....	37
9.7.A	Ballast Bag.....	37
9.7.B	Ballast Box.....	37
9.7.C	Common Ballast .....	37
9.7.D	Ballast Access .....	37
9.7.E	Ballast Type .....	37
9.8	Solar Car Markings .....	38

9.8.A	Team Numbers .....	38
9.8.B	Institution Name(s) & Sponsors .....	38
9.8.C	Event Logo .....	38
9.8.D	National Flag .....	38
9.8.E	Front Signage .....	38
<b>10.</b>	<b>Mechanical .....</b>	<b>39</b>
10.1	Body Panels .....	39
10.1.A	Covers and Shields .....	39
10.1.B	Clearance .....	39
10.1.C	Array Attachment .....	39
10.2	Tire and Wheel Requirements .....	39
10.2.A	Wheel Configuration .....	39
10.2.B	Design Intent .....	39
10.2.C	Static Stability .....	39
10.2.D	Tires .....	40
10.2.E	Wheels/Rims .....	40
10.3	Cockpit .....	40
10.3.A	Occupant Cell .....	40
10.3.B	Occupant Seats .....	41
10.3.C	Occupant Space .....	42
10.3.D	Belly Pan .....	42
10.3.E	Safety Belts .....	42
10.4	Fasteners .....	45
10.4.A	Bolts .....	45
10.4.B	Securing of Fasteners .....	45
10.4.C	Securing Rod Ends .....	45
10.4.D	Buckles and Straps .....	45
10.4.E	Critical Areas .....	45
10.4.F	Hub Nuts .....	45
10.5	Brakes .....	46
10.5.A	Configuration .....	46
10.5.B	Brake Pads .....	46
10.5.C	Braking Performance .....	46
10.5.D	Brake Lines/Cables .....	46
10.5.E	Pedal Position .....	46
10.5.F	Hand Activated Brakes .....	46
10.5.G	Cars with Mechanical Rear Brake .....	46
10.6	Parking Brake .....	47
10.6.A	Performance .....	47
10.6.B	Independence .....	47
10.6.C	Locking .....	47
10.6.D	Contact Style .....	47
10.7	Steering .....	47
10.7.A	Steering Wheel .....	47
10.7.B	Steering Stops .....	47
10.7.C	Turning Radius .....	47
10.7.D	Steering Backlash .....	47
10.8	Towing Hardpoint .....	47
10.9	Dynamic Stability .....	48
10.9.A	Figure-8 .....	48
10.9.B	Stability at Speed .....	48
10.9.C	Slalom Test .....	48
10.9.D	Brake Test .....	49
10.9.E	Acceleration Test .....	49
10.9.F	Disqualification of a Driver .....	49
<b>11.</b>	<b>Occupant Requirements .....</b>	<b>50</b>
11.1	Occupant Registration .....	50
11.1.A	Drivers .....	50
11.1.B	Passenger .....	

s 50

- 11.2 Helmets ..... 50
- 11.3 Shoes ..... 50
- 11.4 Duration in Car ..... 50
- 11.5 Water/Fluids ..... 50
- 11.6 Driver Communication ..... 50
  - 11.6.A Driver Communications ..... 50
  - 11.6.B Cell Phone Use ..... 51
  - 11.6.C Solar Vehicle Driver Communication ..... 51

**SECTION 3 – OPERATIONS ..... 52**

**12. FSGP Operations ..... 53**

- 12.1 Track Event Format ..... 53
- 12.2 Determination of Single-Occupant Vehicle Winner ..... 53
- 12.3 Determination of Multi-Occupant Vehicle Winner ..... 53
  - 12.3.A Person-Mile Distance (D) ..... 53
  - 12.3.B External Energy Usage (E) ..... 53
  - 12.3.C Completion Factor (C) ..... 53
  - 12.3.D Target Speed Derate (T) ..... 53
- 12.4 Solar Car Configuration ..... 54
- 12.5 Radios / Communication ..... 54
- 12.6 Authority ..... 54
- 12.7 Safety ..... 54
  - 12.7.A Safety Equipment ..... 54
  - 12.7.B Support Vehicles ..... 54
  - 12.7.C Safety Vehicles ..... 54
- 12.8 Briefings ..... 54
- 12.9 Timing ..... 54
  - 12.9.A Responsibility ..... 54
  - 12.9.B Timers ..... 54
  - 12.9.C Official Time ..... 54
  - 12.9.D Track Hours ..... 55
- 12.10 Starts ..... 55
  - 12.10.A Group Start ..... 55
  - 12.10.B Starting Order ..... 55
  - 12.10.C Start Line ..... 55
  - 12.10.D Delayed Start ..... 55
- 12.11 End of Day ..... 55
  - 12.11.A End of Day ..... 55
- 12.12 Charging/Impound ..... 55
  - 12.12.A Charging ..... 55
  - 12.12.B Impounding ..... 56
- 12.13 Driving Procedures ..... 56
  - 12.13.A Speed Limit ..... 56
  - 12.13.B Following Too Closely ..... 56
  - 12.13.C Pushing ..... 56
- 12.14 Breakdowns ..... 56
- 12.15 Track Operation ..... 57
  - 12.15.A Flags ..... 57

**13. Penalties ..... 58**

- 13.1 Penalty Distance/Laps ..... 58
  - 13.1.A Penalty Distance ..... 58
  - 13.1.B Penalty Laps (Track Event) ..... 58
  - 13.1.C Scrutineering Issues ..... 58
  - 13.1.D Posting of Penalties ..... 58
- 13.2 Protests ..... 58
  - 13.2.A Opportunity to Be Heard ..... 58
  - 13.2.B Time Limit ..... 58
  - 13.2.C Protest Judgements ..... 58
- 13.3 Conduct ..... 59

13.4 Penalties .....	59
13.4.A Speeding.....	59
13.4.B Track Operation Violation .....	59
13.4.C Failure to Allow Other Solar car to Pass .....	59
13.4.D Pushing .....	59
13.4.E Improper Ballast.....	59
13.4.F Unauthorized Drivers / Occupants.....	59
13.4.G Driving Outside of the Event Day .....	59
13.4.H Non-Solar Charging of Batteries.....	59
13.4.I Disturbing Official Battery Seals .....	59
13.4.J Replacement of Batteries .....	59
13.4.K Failure to Impound.....	60
13.4.L Exceeding Size Specifications.....	60
13.4.M Securing of Fasteners.....	60
13.4.N Parking Brake Penalty .....	60
13.4.O Roll Cage Clearance Penalty .....	60
13.4.P Ignoring BPS Fault Indicator.....	60
<b>Appendix A. Steering Wheel Specifications.....</b>	<b>61</b>
<b>Appendix B. Occupant Space Diagram .....</b>	<b>62</b>
<b>Appendix C. Reference Standard for Lighting .....</b>	<b>63</b>
<b>Appendix D. PVDR - Instructions.....</b>	<b>64</b>
<b>Appendix E. Mechanical PVDR Form .....</b>	<b>65</b>
<b>Appendix F. Mechanical Report Instructions .....</b>	<b>66</b>
<b>Appendix G. Mechanical VDR Form .....</b>	<b>69</b>
<b>Appendix H. Battery Approval Form.....</b>	<b>71</b>
<b>Appendix I. Solar Cell Report.....</b>	<b>72</b>
<b>Appendix J. Recommendations .....</b>	<b>73</b>
<b>Appendix K. Multi-Occupant Vehicle Practicality Judging.....</b>	<b>74</b>
<b>Appendix L. Onboard MOV Energy Meter Overview.....</b>	<b>75</b>
<b>Appendix M. Revision Table .....</b>	<b>77</b>

# **SECTION 1 - ADMINISTRATION**



# 1. Purpose

## 1.1 Fundamental Vision

The Formula Sun Grand Prix (FSGP), hosted by the Innovators Educational Foundation (IEF), seeks to promote and celebrate educational excellence and engineering creativity. Fueled by the spirit of friendly competition and teamwork, the FSGP champions the creative integration of technical and scientific expertise across a range of exciting disciplines.

## 1.2 Missions

To support and encourage bright young minds to succeed in the technical fields of engineering, the sciences, mathematics, and business, through multi-disciplined experiential learning which in turn enables success in future careers.

To create public awareness and enthusiasm, both for education excellence and engineering creativity itself, and for the technologies and practices that emerge from that excellence.

# 2. Administration

## 2.1 Organizers

### 2.1.A Organizers

The Innovators Educational Foundation (IEF) shall be the official Organizers of the Formula Sun Grand Prix (the "Event"), and shall be responsible for all management oversight and application of the Regulations for the Event. The Formula Sun Grand Prix is not in any way associated or affiliated with the Formula 1 companies, FORMULA 1 racing, or the FIA Formula One World Championship.

### 2.1.B International Solarcar Federation

The Formula Sun Grand Prix and the American Solar Challenge are recognized as International Solarcar Federation (ISF) events.

## 2.2 Event Website

For official information about the Events, registration documents, regulations, participating teams, sponsors, and contact information, visit <https://www.AmericanSolarChallenge.org>. Teams that maintain an internet presence are requested to incorporate a link to the Event Website.

## 2.3 Headquarters

During the Event, a Headquarters will be established at a site appropriate to each Event component and will assume the management functions for the Event.

## 2.4 Officials

A team of Officials to conduct the Event including all event components will be selected by the Organizers. Officials having specific duties shall be announced to the teams through the Event briefings.

### 2.4.A Event Director

The Organizers will appoint an Event Director who has responsibility for the Event.

### 2.4.B Regulations Manager

The Organizers will appoint an individual for the role of the Regulations Manager. The Regulations Manager reports to the Event Director, and to the Organizers and is responsible for the Regulations of the Event.

### 2.4.C Chief Inspector

The Organizers will appoint an individual to serve in the role of the Chief Inspector. The Chief Inspector reports to the Event Director, and to the Organizers and is responsible for the technical inspections of the solar cars and enforcement of the Regulations.

## 2.4.D Head Timekeeper

The Organizers will appoint an individual to serve in the role of Head Timekeeper. The Head Timekeeper reports to the Chief Inspector, and to the Organizers and is responsible for the timing and scoring during the Event.

## 2.4.E Technical, Safety and Fairness Officials

The Event Director, Chief Inspector, Regulations Manager and Head Timekeeper will appoint additional Officials to conduct the Event.

**2.4.E.1 Inspectors:** Several Officials will be assigned the role of “Inspector” who have the responsibility to perform technical inspections of the solar cars and enforce the Regulations.

**2.4.E.2 Staff:** A team of “Staff” will support the Event and will be Officials during the Event.

**2.4.E.3 Track Steward:** During the track portion of the Event, an Official will be named the “Track Steward”. The Track Steward will be in control over operations of the track. The Track Steward will have the same authority as the Chief Inspector for track operation.

## 2.4.F Jury

A Jury will be formed to evaluate protests on conformity with these Regulations, to resolve team disputes, and rule on penalty appeals. In addition, the Jury is empowered to decide cases not specifically covered by these Regulations. The Jury will be available to teams during the Event. The Jury will consist of a minimum of three (3) distinguished individuals who have experience with solar car events

## 2.5 Application of Regulations

These Regulations will apply to the Formula Sun Grand Prix, which includes the selection of teams, registration of teams, the inspection of solar cars (“Scrutineering”), and the on-track event (the “Track Event”).

## 2.6 Supplemental Documents

### 2.6.A Additional Documents

Additional documents may be distributed to all teams entered in the Event to supplement these Regulations. These documents will clearly state that they are a supplement to the Regulations and they will have the same force and effect as these Regulations.

### 2.6.B Conflict

If there is a conflict between a supplemental document and these Regulations, the document having the later date shall take precedence. The Organizers reserve the right to revise these Regulations at any time.

## 2.7 Acceptance of Regulations

All persons or groups selected to participate in the Event are assumed to know these Regulations. Their participation in the Event will constitute acceptance of them.

## 2.8 Event Cancellation

The Organizers reserve the right to cancel, abandon, or postpone the event, in whole or in part, for any reason, including but not limited to acts of God, natural disasters, acts of war, acts of terrorism, weather, riots, strikes, communicable disease crisis, quarantine restrictions, and other events beyond the control of the Organizers.

## **2.9 Interpretation of Regulations**

### **2.9.A Interpretation**

Only the Regulations Manager, Chief Inspector, and Inspectors are authorized to interpret the Regulations.

### **2.9.B Official / Unofficial Interpretations**

**2.9.B.1** Teams shall identify if their question constitutes an Official or Unofficial Interpretation request.

**2.9.B.2** Official Interpretations will be responded to such that all teams will have visibility to the question and response.

**2.9.B.3** Official Interpretations will have the same force and effect as the Regulations.

**2.9.B.4** Unofficial Interpretations of the Regulations will be kept private between the team and the Inspectors.

**2.9.B.5** Unofficial Interpretations will have no force and effect on the Regulations and may be superseded.

### **2.9.C Prior to Scrutineering**

**2.9.C.1** Teams requesting interpretation of the Regulations shall submit their question(s) to the Inspectors through email at: [ascregs@americansolarchallenge.org](mailto:ascregs@americansolarchallenge.org)

**2.9.C.2** All Official Interpretations will be posted to the Internet under “Official Interpretations” on the Event Website.

### **2.9.D During and after Scrutineering**

**2.9.D.1** All Official Interpretations will be announced at Briefings as well as on the Event Website.

## **2.10 Advertising, Promotion, and Publicity**

All advertising, sales promotion, and publicity material produced by the teams or their sponsors concerning or referring to the Event will refer prominently to the Event as “The Formula Sun Grand Prix”. If in fact a naming sponsor is secured, teams will be required to append the Sponsor Name and to display the entire Event name, i.e. “The Acme – Formula Sun Grand Prix”. All teams, by entering the Event, specifically agree to abide by this regulation. Furthermore, by entering the Event, all teams and team members agree to the use of their names and their likenesses in any publicity materials (brochures, magazines, videos, photographs, etc.) that may be issued by the Event’s sponsors or Organizers.

## 3. Safety

Each team is responsible for the road-worthiness of its solar car. Passing Event components of Scrutineering or implementing changes suggested in comments on the team's technical documents does not relieve the team of any liability.

All solar cars and support vehicles must be maintained in a safe, road-worthy condition and be operated safely and within the law at all times. A team may be disqualified and withdrawn from the Event at any time if it is judged to be operating in an unsafe manner. All solar cars and support vehicles are operated and driven at the team's own risk.

Each team is responsible for the safety of its members, and any minimum criteria specified by the Organizers via these Regulations and/or correspondence between the teams and the Organizers should not be construed as design specifications for the construction of a "safe" solar vehicle.

Teams must look after the health and safety of their team members.

### 3.1 Team Safety

#### 3.1.A Team Safety Officer

**3.1.A.1** Each team is required to have at least one Safety Officer.

**3.1.A.2** All Safety Officers shall be trained in basic First Aid including CPR. Proof of training shall be submitted to Headquarters with their Team Data Sheet (available on the Event Website).

**3.1.A.3** At all times, one of the team's Safety Officers must be the Designated Safety Officer. The Designated Safety Officer may not hold the role of Solar Car Driver, Support Vehicle Driver, or Team Manager while acting as the Designated Safety Officer. The Designated Safety Officer must be present in the pit area while the Solar Car is on the track.

*It is encouraged to have more than one team member who is trained in basic First Aid including CPR.*

#### 3.1.B Team Safety Kit

**3.1.B.1** Each team shall have available the following safety kit:

- (1) First-aid kit meeting ANSI Z308.1 Class A or B, Type III or IV;
- (2) Safety vests (1 per occupant);
- (3) ABC fire extinguishers (30 lb / 13.5 kg active material capacity or larger);
- (4) Battery MSDS;
- (5) Battery spill kit / method of containment of battery fires / 40 kg of sand;
- (6) A shovel/spade (for applying the sand);
- (7) Safety glasses and gloves for handling batteries; and,
- (8) A 5 gallon metal bucket for inerting and disposal of damaged electrochemical cells.

**3.1.B.2** The above safety kit shall be located at the pit while the solar car is on the track for FSGP. Items 4 through 8 should travel with the solar car between Scrutineering stations.

**3.1.B.3** The team shall ensure that applicable Personal Protective Equipment (PPE) is used for fabrication, repairs etc., i.e. safety glasses, cut resistant gloves etc.

## 4. Entries

### 4.1 Event Registration

The Event is only open to institutions of higher education (participants). No participating team will be considered fully registered until all items below are received by Headquarters and marked Green on the Team Status Board on the Event Website.

#### 4.1.A Registration - Initial Registration Package

4.1.A.1 Each team wishing to participate must submit an Initial Registration Package consisting of:

- (1) Team Entry Form;
- (2) Team Participation Agreement;
- (3) Proof of Insurance;
- (4) Preliminary Vehicle Design Report (as described in Reg. 5.1); and,
- (5) The initial entry fee, US\$1900.

4.1.A.2 This portion of the entry fee is non-refundable. Inspectors are not obligated to grade Technical Documentation reports for teams who have not yet paid the Initial Entry Fee and they will prioritize teams who have paid this fee.

#### 4.1.B Registration – Track Registration Package

4.1.B.1 Each team participating in the Event must submit a track registration package consisting of:

- (1) Vehicle Design Report (as described in Reg. 5.2); and,
- (2) the track fee, US\$4150.

4.1.B.2 This portion of the entry fee is non-refundable.

#### 4.1.C Grants

Teams with demonstrated financial need, and technical potential, may apply for a grant from the Event Organizers to cover a portion of their entry fees. Teams will be required to submit a proposal detailing their request for Grant funding. The proposal form will be provided to the team upon request. Award of a Grant is at the discretion of the Organizers.

#### 4.1.D Donations

Teams that withdraw after making payment will have funds considered as donations to the Innovators Educational Foundation in consideration that no services or goods are provided for said funds.

#### 4.1.E Team Members

The entry fees consider up to fifteen (15) team members.<sup>1</sup> Beyond this number an additional fee of US\$70 per additional team member will be assessed.

#### 4.1.F Supporters and Additional Team Members

The Organizers reserve the right to determine if any individual is acting de facto as part of a team.

---

<sup>1</sup> It is understood that team members may arrive and depart from the Event at various times. The number of team members listed in the regulation is the total number registered, not the number of team members attending at any one time.

## 4.2 Team Data

Each team must submit a team photo and data sheet to Headquarters by the date in Reg. 4.3.A.3. The photo and data can be publicly released and used in Event brochures. Late submissions will be omitted. Early submissions will not be made public prior to the date in Reg. 4.3.A.4 without permission of the team representative. After this date team information can be released by Headquarters.

### 4.2.A Team Photo

Each team shall provide a digital team photo that must clearly show the solar car and team members. Team members in the photo must be identified by name and by their institution when there is more than one institutional sponsor. The photos will be used in the Event programs and other publications. In addition to the photo, teams must submit a filled-out Team Photo form which can be downloaded from the Team Status Board on the Event Website.

### 4.2.B Data Sheets

Each team shall provide a data sheet which must include solar car mass (road-ready, without occupants), solar car dimensions, motor type and rating, solar cell type and manufacturer, estimated solar collector power at STC from the Solar Cell Report (Appendix I), battery mass and nominal capacity from the Battery Approval Form (Appendix H), chassis description, braking system, and wheel type and size. All specifications must be provided in metric units (SI). The team leader, crew members, safety officer(s), designated solar car drivers/passengers, and faculty advisor(s) must also be listed. A copy of the front of each solar car driver's valid Drivers License must be provided with the Team Data Sheet. See Reg. 3.1.A for Safety Officer requirements including submission of proof of First Aid/CPR training with the Team Data Sheet.

## 4.3 Registration Deadlines

### 4.3.A Registration Dates

- 4.3.A.1 Initial registration package is due: November 15, 2024
- 4.3.A.2 Track registration package is due: January 31, 2025
- 4.3.A.3 Team Data Sheet and Photo are due: May 1, 2025
- 4.3.A.4 Public Release of Team Data Sheets and Photos: May 15, 2025
- 4.3.A.5 Build Review is due: May 30, 2025

### 4.3.B Late Penalties

Late fees will be imposed for fees and reports received more than ten (10) days beyond the published deadline.

- 4.3.B.1 A US\$200 fee will be imposed for late submission of the Initial Registration Package.
- 4.3.B.2 A US\$400 fee will be imposed for late submission of the Track Registration Package.

### 4.3.C Entry Fee Payments

**4.3.C.1 Transaction Fees:** Any additional fees resulting from payments made to IEF for entry into the Event shall be the responsibility of the team making payment utilizing such methods incurring added fees.

**4.3.C.2 Foreign Currency:** It is the responsibility of the team for making payment in US currency. IEF does not guarantee acceptance of payments made in any currency other than US dollars.

**4.3.C.3 Payment Via ACH:** If your school has the ability to make electronic ACH payments, this can be a good option for quick payments without transaction fees. To start the process of adding IEF as a vendor for ACH payments, have your school's procurement person contact [ief@americansolarchallenge.org](mailto:ief@americansolarchallenge.org).

**4.3.C.4 Payment Via Check:** Make checks payable to Innovators Educational Foundation and mail them to the IEF address listed on the Event Website.

**4.3.C.5 Payment Via PayPal:** Teams can pay with a credit/debit card or bank account using PayPal. This results in transaction fees of US\$0.49 per payment plus 1.99% of the transaction (or 3.49% for payments from outside the United States). To use this method, first calculate the PayPal Transaction Amount using the following formula and then pay this amount to [ief@americansolarchallenge.org](mailto:ief@americansolarchallenge.org) in USD.

Domestic US PayPal Payment Amount = ( Payment Due + 0.49 ) / 0.9801

International PayPal Payment Amount = ( Payment Due + 0.49 ) / 0.9651

**4.3.C.6 Payment Via Wire Transfer:** A US\$50 wire transfer transaction fee shall apply to all wire transfers, which covers IEF bank fees for accepting incoming wire transfers. This fee is in addition to any transaction fees charged by the issuing bank and should be included with the payment. Contact [ascteams@americansolarchallenge.org](mailto:ascteams@americansolarchallenge.org) if your team is interested in paying via Wire Transfer.

**4.3.C.7** Payments made will be applied against the registration packages in order, i.e. payment will be applied to the Initial Registration Package first, followed by the Track Registration Package etc.

## 4.4 University/College Advisor

### 4.4.A University/College Advisor

**4.4.A.1** All teams must have at least one University / College advisor ("Advisor") who will provide guidance as needed throughout the solar car design, building, and testing process.

**4.4.A.2** The University / College advisor shall be an employee of the educational institution be it a University or College etc., that is the official acting on behalf of the institution representing the participating entry into the Event.

**4.4.A.3** The Advisor will be the official contact between the Event and educational institution.

**4.4.A.4** It is strongly recommended that the Advisor attend the Event.

## 4.5 Event Correspondence

### 4.5.A Primary Team Contacts

Communication with Event Officials shall be conducted in English, the official language of the Event, by team leaders (Faculty Advisor, Project Manager, & Department Leads) as detailed on the Team Entry Form.

### 4.5.B Emails

**4.5.B.1** Email is the preferred communication method for Event correspondence. Participating institutions must set up a Generic Team Email account for this purpose that forwards messages to the current team leaders (Faculty Advisor, Project Manager, & Department Leads). The team is responsible for ensuring that as team leaders are replaced the email forwarding is updated accordingly.

**4.5.B.2** The Generic Team Email address must be included on all email correspondence between any team member and any Event representative.

## 4.6 Insurance

All teams need to maintain vehicular liability and general public liability insurance with limits of liability for (1) bodily injury of not less than US\$1,000,000.00 for each person and US\$1,000,000.00 for each occurrence, and for (2) property damage of not less than US\$1,000,000.00 for each accident and US\$1,000,000.00 in the aggregate. Teams will be required to provide a certificate of such insurance or proof of self-insurance.

## 4.7 Withdrawals and Exclusion

### 4.7.A Voluntary

The Faculty Advisor or Project Manager of any team wishing to withdraw must notify Headquarters in writing.

### 4.7.B Not Meeting Requirements

Headquarters may withdraw teams that do not meet the registration deadlines or fail to present a solar car that satisfies Scrutineering or Event requirements.

### 4.7.C Exclusion

Exclusion will occur if the Officials deem a team to have departed from the spirit of the Event by deliberately acting to gain unfair advantage over other teams or to have acted in an unsafe manner.

## 4.8 Team Numbers:

Each team registered for the Event will have a unique number approved by Headquarters (positive integer, three (3) digits maximum).

**4.8.A.1 Number Retention / Reservation:** Teams which have participated in four (4) or more previous ASC (Sunrayce, NASC) cross-country events have the right to reserve their team number from those openly available for selection by other teams. The number being selected for reservation must be the number used in the four (4) events.

**4.8.A.2** Requests to reserve a number shall be made in writing to Headquarters, with a listing of the events which the team attended and team number.

**4.8.A.3** Team numbers (either use of a reserved number or new unallocated number) will be confirmed as team's complete registration paperwork and submit entry fees.

**4.8.A.4 Number Conflict:** If a conflict in team numbering arises, Headquarters will determine the numbers assigned. Resolution will be based on order of requests and payment of entry fees with respect to when the team number request is made. If a team fails to pay their entry fees on schedule their requested number can become available to another team who is current on their payments.

**4.8.A.5 Tracking of Reserved Numbers:** Headquarters will track the Reserved Numbers, and will post a list of the Reserved Numbers and the corresponding team on the Event Website.

**4.8.A.6 Unallocated Reserved Numbers:** Should a team with a reserved number desire to change their number, the previously reserved number will become unallocated and available to other teams. A team cannot have more than one reserved number.

## 4.9 Participant Registration

All participants in the Event must be registered with Headquarters. This includes team members, sponsors, officials, guests, and the media. All participants must present themselves at Registration to complete all required forms. Badges will be issued and used to obtain access to restricted areas. These badges must be visible at all times.



## 5. Technical Documentation

### 5.1 Preliminary Vehicle Design Report (PVDR)

A preliminary vehicle design report must be submitted to Headquarters by the date indicated in Reg. 4.3.A.1. The report shall include a preliminary design review of your vehicle's mechanical, electrical systems and proposed battery, instructions are provided in Appendix D and Appendix E.

#### 5.1.A PVDR Contents

The report shall include the preliminary design information on the structural chassis and roll cage providing protection to the driver, as well as an overview of the electrical approach to the solar car and proposed battery system. Particular attention will be given to:

- 5.1.A.1 Mechanical Team leader contact information (phone & email)
- 5.1.A.2 Roll over and impact protection for the driver
- 5.1.A.3 Windshield material selection and data sheet
- 5.1.A.4 Electrical Team leader contact information (phone & email)
- 5.1.A.5 An overview of the electrical approach to the solar vehicle
- 5.1.A.6 A preliminary electrical diagram showing greater than 24-volt service plans
- 5.1.A.7 Preliminary battery approval document including the battery team leader contact information (phone & email & battery manufacturer URL)
- 5.1.A.8 Battery types and suppliers/manufacturers' being considered if one is not already chosen
- 5.1.A.9 Battery testing plans with critical dates

### 5.2 Vehicle Design Report (VDR)

A vehicle design report including technical documents describing the solar car's mechanical systems, electrical systems, batteries, and solar cells must be submitted to Headquarters for approval by the date indicated in Reg. 4.3.A.2. Early submissions will receive prompt review and feedback by Headquarters. Early submissions may be sent as individual technical documents for review without the complete vehicle design report. The information contained in each team's final submission must match the solar car presented at Scrutineering. Safety should be the primary concern with regard to the structural development and fabrication of the solar cars.

#### 5.2.A Document Format

Vehicle design reports shall be submitted as PDF documents with a different file for each of the five (5) technical reports. PDF file names shall be formatted as: Sponsoring Organization Name\_FSGP2025VDR\_Report Type. Example: a mechanical report from the University of ACME may appear as "UnivOfACME\_FSGP2025VDR\_MechanicalTechnicalReport.pdf" with the first letter of each new word capitalized and common abbreviations accepted.

#### 5.2.B Mechanical Technical Report

A detailed mechanical technical report must be submitted to Headquarters as part of the Vehicle Design Report by the date indicated in Reg. 4.3.A.2. The mechanical tech report must present the as-built design; addressing:

- 5.2.B.1 Design issues involved in impact, roll over and suspension scenarios
- 5.2.B.2 Address vehicle stability, including center of gravity and relative weights on each wheel.

Documentation with calculations and/or testing should be provided. Photos, drawings and anecdotal references are acceptable. The entire technical document including appendices shall not exceed thirty (30) pages (not sheets) in length. Detailed instructions are provided in Appendix F.

- 5.2.B.3 Include completed design review form from the Team Status Board on the Event Website.

## 5.2.C Electrical System Technical Report

An electrical system technical report must be submitted to Headquarters as part of the Vehicle Design Report by the date indicated in Reg. 4.3.A.2. The tech report must document the electrical design approach. The tech report must include:

**5.2.C.1** A functional system diagram and rough schematic showing all essential power circuits and electrical equipment, including the Solar Array of the solar car in schematic form. The drawing should include power generation devices (array, regen, etc.), power storage (batteries, etc.), Main Power Switching and isolation mechanisms, battery protection systems, motor, motor controller, Battery Fuse and any auxiliary circuits. MOVs must also include the details for their onboard charging systems, and must provide details on methods of securing the battery inside the car for impound purposes. Provide system power requirements, fuse specification sheet, high power wiring specification to support fuse & wiring selection. Anything not presented from Reg. 5.1.A.7 PVDR is also required in this report.

**5.2.C.2** Battery Approval Forms for each battery type

## 5.2.D Battery Tech Report

All storage batteries used in the solar car must be approved by Headquarters. The battery tech report must be submitted to Headquarters as part of the Vehicle Design Report by the date indicated in Reg. 4.3.A.2. Capacity will be based on manufacturer's data. If an intermediate supplier is used, submit only the cell manufacturer's data as required on the Battery Approval Form. Battery Approval Forms shall be provided on the Event Website, and in Appendix H. Please note the definitions included in Reg. 8.3.A. Each team must provide a copy of the manufacturer's battery specification sheet, the Material Safety Data Sheet (MSDS) obtained from the battery manufacturer, and a battery approval form with the following battery information in the tech report:

**5.2.D.1** Manufacturer's name, contact information, and Cell Specification URL for the cell Manufacturer and MSDS.

**5.2.D.2** Stock number, type, or description

**5.2.D.3** Cell & Module voltage (e.g., 1.2, 4, 6, 12, or 24 V)

**5.2.D.4** Bus voltage

**5.2.D.5** Number of cells per module, modules per strings, strings in parallel, and total cell count

**5.2.D.6** Manufacturer's specifications, including capacity (kWh), weight (kg), and cost (US\$)

**5.2.D.7** Spill/damage protocols and procedures (if these are not provided in the MSDS then the team must obtain this information from the manufacturer and submit it to Headquarters with the MSDS)

**5.2.D.8** A description of the battery box(es) and their mounting. Include the chemical compatibility of the box material and the electrolyte in case of leakage

**5.2.D.9** Battery Approval Form for each battery type

**5.2.D.10** Description of emergency procedures for a fire in the solar car that is noticed from the chase vehicle.

## 5.2.E Battery Protection Tech Report:

All batteries must be protected with technology appropriate to the chemistry used. The battery protection tech report must be submitted to Headquarters as part of the Vehicle Design Report by the date indicated in Reg. 4.3.A.2. The tech report must document the design approach used with respect to Reg. 8.3 including the following information:

- 5.2.E.1 Battery Approval Forms for each battery type
- 5.2.E.2 Battery pack configuration including cells per module, modules per strings, strings in parallel, and total cell count
- 5.2.E.3 Over temperature set points (charge and discharge if different) for each battery type
- 5.2.E.4 Under voltage set point for each battery type
- 5.2.E.5 Over voltage set point for each battery type
- 5.2.E.6 Over current set point for each battery type (charge and discharge if different)
- 5.2.E.7 Block diagram for BPS and component within battery enclosures for each battery type
- 5.2.E.8 Description of how the BPS will operate for start-up and fault conditions for each battery type
- 5.2.E.9 How firmware or settings will be rendered static and un-modifiable after inspection (i.e. sealed in battery enclosure)
- 5.2.E.10 Describe function of driver dash and BPS fault strobe for External Cutoff switch, ref. Reg. 8.6.C

## 5.2.F Solar Cell Tech Report

Solar cell tech reports must be submitted to Headquarters as part of the Vehicle Design Report by Reg. 4.3.A.2. Each team must provide a copy of the manufacturer's solar cell specification sheet with the following solar cell information in the tech report:

- 5.2.F.1 Manufacturer's name and contact information
- 5.2.F.2 Stock number, type, or description
- 5.2.F.3 Manufacturer's quote for cell area (cm<sup>2</sup>)
- 5.2.F.4 Manufacturer's quote for performance
- 5.2.F.5 Cell area (cm<sup>2</sup>)
- 5.2.F.6 A detailed layout map of the vehicle, showing all cell types/sizes and locations, as well as calculations of total area

## 5.3 Grading of Team Reports

Team documents will be reviewed by the Inspectors and a color grade will be given to each document on the Team Status Board with the following general meanings:

- (1) Green – Requirement Completed: Submission is accepted – no further action required
- (2) Yellow – Minor Action Required: Submission is insufficient – Some revision to design or additional reporting is required – Resubmit with requested revisions
- (3) Red – Significant Action Required: Submission is overdue, incomplete, or rejected – Significant revision to the design or significant additional reporting is required – Submit valid and complete information ASAP

VDR submissions will not be reviewed before the team has a Green status on the relevant section of their PVDR. Green report status does NOT assure passing Scrutineering as not all aspects of a design can be fully reviewed during evaluation of written reports. All solar cars are subject to a detailed Scrutineering inspection at the Event.

## 5.4 Build Review

Each team must engage an experienced engineer or academic, responsible for reviewing and certifying that the solar car is designed and constructed using sound engineering practice, meets the design parameters where stated, and is roadworthy and fit for the purpose of being driven in the event(s). A form will be provided on the Team Status Board on the Event Website. The build review shall also include photographs of the vehicle in the state in which it was reviewed. Failure to submit this completed form, showing all items in full compliance, by the due date in 4.3.A.5 shall result in a team dropping to the back of the queue for scrutineering slots. Teams shall not begin the Scrutineering process before their completed Build Review is received.

## 6. Event Components

### 6.1 Scrutineering

#### 6.1.A Acceptance at Scrutineering

Only teams who have obtained Green status on their Event Registration Submissions and who have paid the required Event fees will be accepted for Scrutineering.

#### 6.1.B Participation at Scrutineering

Each team registered for the Event must submit their entry for inspection prior to the Event to verify compliance with these Regulations. In addition, spot checks for Regulation compliance may take place during and immediately after the Event. The top five overall finishing cars in each class may be impounded immediately following the Event for a final inspection at the discretion of the Inspectors.

#### 6.1.C Scrutineering Time and Location

The date and location of Scrutineering shall be posted on the Event Website. The inspection schedule will be announced prior to the start of Scrutineering with the inspection slot order randomly determined within the following framework. The first five teams to obtain all Green status on the Team Status Board will be given preferential inspection slots. At the time the Scrutineering Schedule is determined, VDR status for each station will be taken into account with Greens getting earlier slots, followed by Yellows, followed by Reds. Any teams who fail to present their Build Review on time will be given last priority inspection slots. Teams that fail to present their solar car at their designated inspection slots or fail to participate in mandatory team meetings may be given last priority for Scrutineering and risk not having enough time to complete the process.

#### 6.1.D Scrutineering Format

Scrutineering will involve inspection stations including body & sizing, driver, electrical, battery protection, array, mechanical, and dynamic tests to verify handling and braking performance. Instructions for Scrutineering and a detailed description of the Scrutineering tests will be distributed in advance to all registered teams.

#### 6.1.E Configuration and Drivers for Scrutineering

All Drivers must be present for designated Scrutineering inspection stations. The driver selection and car configuration are at the discretion of the Inspectors for each station. Teams may be required to repeat tests with different drivers and/or configurations as directed by the Inspectors. Different numbers of passengers qualify as different configurations for MOVs.

#### 6.1.F Scrutineering Status

Teams will be graded after each Scrutineering station inspection with a status color as follows:

- (1) Green – Team has passed station
- (2) Blue – Improvement needed / cleared for track with penalty condition
- (3) Yellow – Improvement needed / cleared for dynamics testing
- (4) Red – Team has failed station / safety issue must be addressed
- (5) Grey – Not Applicable to Team

## 6.2 The Track Event

### 6.2.A Participation at the Track Event

The Track Event is an on-track competition that is open to teams who have met all Scrutineering requirements and who have paid the full Event fee. Track Event Regulations are provided in Reg. 12.

### 6.2.B Acceptance at the Track Event

Only teams who have obtained Green or Blue status for each Scrutineering Inspection Station will be accepted at FSGP.

## 7. Vehicle Classes

Three (3) classes of solar vehicle will be recognized as part of the Event:

- (1) Single-Occupant;
- (2) Multi-Occupant; and,
- (3) Demonstration.

### 7.1 Vehicle Class Definitions

#### 7.1.A Single-Occupant (SOV)

This class comprises solar powered vehicles designed for a single-occupant. These vehicles are akin to the "Challenger" class of vehicles from the Bridgestone World Solar Challenge.

#### 7.1.B Multi-Occupant (MOV)

This class comprises solar powered and grid-charge vehicles designed for multiple-occupants. These vehicles are akin to the "Cruiser" class of vehicle from the Bridgestone World Solar Challenge.

#### 7.1.C Demonstration (DEMO)

**7.1.C.1** Vehicles in this class must have entered, passed scrutineering, and qualified for ASC, FSGP or another recognized solar car event within four calendar years prior to the current Event, OR, they must be designed to released regulations for an upcoming solar car event.

**7.1.C.2** Vehicles in this class will be scrutineered to the regulation set they were designed to and will be subject to additional regulations associated with safety from the Single-Occupant and Multi-Occupant class vehicle technical regulations.

**7.1.C.3** This class is for demonstration only. Vehicles in this class will not be scored or ranked.

## **SECTION 2 – TECHNICAL**

## 8. Power

Natural solar radiation received directly by the solar collector is the only source of energy that can be used for propulsion, except for energy stored in the solar car's battery system at the beginning of the Event or metered AC charging of MOVs. Energy recovered from the motion of the car during Track hours may also be used.

### 8.1 Solar Collector

#### 8.1.A Cell Type

Only commercially available silicon based photovoltaic cells may be used.

#### 8.1.B Solar Collector Size Limits

The solar collector cannot exceed a maximum of 4.000 m<sup>2</sup> for Single-Occupant class solar cars, and 5.000 m<sup>2</sup> for Multi-Occupant class solar cars.

#### 8.1.C Definition of Area

Solar collectors will be measured by summing the total area of each solar cell (including all exposed bus bars, junctions and internal structure) from manufacturer's data sheets, validated through measurements.<sup>2</sup>

#### 8.1.D Concentrators

If the solar collector comprises of photovoltaic cells used with concentrators such as reflectors or lenses then the total aperture of the solar collector must not exceed the allowable total area for non-concentrator photovoltaic solar collectors. Teams wishing to use concentrator photovoltaic solar collectors must contact Headquarters for more information.

#### 8.1.E Maximum Number of Cell Types and Sizes

Teams may use no more than six (6) types or sizes of solar cells.

#### 8.1.F Validation Documentation

At Scrutineering, teams must provide sample cells of each type and size installed on the vehicle as well as a detailed map of the vehicle array for validation per Reg. 5.2.F.

#### 8.1.G Solar Collector Connection and Stands

**8.1.G.1** All portions of the solar collector, physical attachment to the solar car, and all electrical connections between the solar collector and the solar car must be carried by the solar car. This includes but is not limited to stands, supports, and cables. This does not include hand tools that do not become part of the solar collector structure.

**8.1.G.2** Stands used for pointing the solar collector while the car is stationary must be self-supporting; stands that rely on people as a means of support will not be allowed. Teams will be required to demonstrate stands at inspection.

*Team members may temporarily steady stands in inclement weather, but it will be obvious to officials if human support of the solar collector becomes routine.*

#### 8.1.H Water Spray

Spraying water on the array between battery impound release time in the morning and battery impound time in the evening (per Reg. 12.12.B) is not allowed. Other "open cycle" cooling methods that rely on energy sources not derived from the car's solar collector are similarly not allowed within this time window.

#### 8.1.I Solar Collector Reconfiguration

The solar collector can only be reconfigured for charging when the solar car is stationary.

#### 8.1.J External Irradiance Amplification

External devices intended to increase the irradiance on the solar collector or increase the efficiency of the solar collector must not be used at any time. Ground sheets used when charging must not increase the irradiance on the solar collector.

---

<sup>2</sup> For the purposes of these Regulations, the area of an uncut Maxeon cell having a width and length of 125 mm and diameter of 160 mm is 153.33 cm<sup>2</sup>. An uncut Maxeon cell having a width and length of 125mm and a diameter of 166 mm is 155.06 cm<sup>2</sup>.

## 8.2 Energy Storage

All solar cars are allowed to store solar-generated energy in an energy storage system composed of individual cells having an energy capacity determined by manufacturer datasheet.

Adherence to storage capacity limits does not imply automatic battery approval. Battery approval forms must be submitted to Headquarters before official approval may be issued. The Inspectors reserve the right to refuse approval of modules. Unaltered samples of individual cells (minimum of three (3)) will be furnished for verification during Scrutineering.

### 8.2.A Battery Capacity Limits

**8.2.A.1** Single-Occupant solar cars are limited to 5.25 kWh of storage capacity, based on the manufacturer datasheets for the storage cells.

**8.2.A.2** Multi-Occupant class solar cars do not have a battery capacity limit.

### 8.2.B Other Energy Storage Methods

Other energy storage technologies not mentioned (such as ultracapacitors or fuel cells) will need to be evaluated by Headquarters. Samples and details of proposed systems must be submitted before the date indicated in Reg. 4.3.A.2.

### 8.2.C Supplemental Batteries

**8.2.C.1** Supplemental, replaceable batteries carried in the solar car may be used to power: Main Power Switch, driver ventilation fans (if solely used for driver ventilation), telemetry, and the horn. All other systems present on the car must be powered off the main battery.

**8.2.C.2** Supplemental battery power must be used to momentarily power the battery protection system (BPS) as defined by Reg. 8.3 to verify safe battery parameters during start up before energizing the Main Power Switch.

**8.2.C.3** During a battery fault in which the BPS has automatically opened the Main Power Switch, the supplemental battery must be used to power the BPS, BPS Strobe, and BPS Fault Driver Indication. While in such a fault state, the supplemental battery may be used to power any other systems (signal lights, rear view camera, telemetry, battery ventilation, etc) that do not provide motive power to the vehicle.

### 8.2.D Commercial Batteries

Commercially available panel meters, cell phones, tablets, driver communication radios, and other electronic devices with their own batteries may be used if the battery is not connected to the vehicle electrical system.

### 8.2.E Other Storage Devices

If any other energy storage devices are used (Reg. 8.2.B), they must be shown to be storing no energy and fully discharged before the start of each Track day.



## 8.3 Protection Circuitry

All batteries must have protection circuitry appropriate for the battery technology used. Proof is required at Scrutineering that the protection system is functional and meets manufacturer's specifications. Testing procedures will be provided, and the protection system design should allow for such testing. All protection circuitry should be contained in the battery enclosures per Reg. 8.4.

### 8.3.A Definitions

**8.3.A.1 Cell:** The smallest available source of energy in the battery pack as purchased from a manufacturer. A single electrochemical cell.

**8.3.A.2 Module:** The smallest grouping of paralleled cells easily removable in a battery pack.

**8.3.A.3 String:** The smallest series of modules that make-up the battery pack required voltage.

**8.3.A.4 Protection Limit:** The measured level determined to be adequate to protect from an event.

**8.3.A.5 Active Protection:** System in which measurements are constantly monitored and where actions are taken immediately without operator intervention to open the Main Power Switch should a Battery Protection Fault occur. Any protection faults will latch such that a manual clearing process is required by the driver with the vehicle not in motion and only after faults have been verified clear by the protection system.<sup>3</sup>

**8.3.A.6 Passive Protection:** System in which measurements are monitored by the driver and where action is driver controlled.

**8.3.A.7 Battery Protection System (BPS):** The system that applies Active Protection to protect battery pack.

**8.3.A.8 Tap:** Wiring that is bonded to an electrical connection point in a circuit for remote voltage or signal measurement

**8.3.A.9 Safe State:** A stable shut down condition where all internal electrical loads connected to the high voltage battery inside the battery enclosure are either isolated or in a high impedance state/off and all external electrical loads are completely disconnected by isolating the high voltage battery pack from all high voltage conductors exiting the battery enclosure.

### 8.3.B Types

**8.3.B.1 Li-Based:** All lithium based battery packs must have **active** protection such that over-voltage, over-temperature (for charge and discharge rating), over-current and under-voltage cause the Main Power Switch per 8.6.A to open and to electrically isolate the source and sink for the vehicle. The level of protection measurement is required down to the module level at a minimum and may be required at a cell level depending on the cell manufacturer. Fuses per Reg. 8.5 are not allowed for battery over-current protection.

**8.3.B.2 Supplemental:** All supplemental batteries must have at a minimum Passive Protection for under voltage where charging occurs remote to the solar vehicle (unless they are primary cells). Active Protection is required if charging is within the solar vehicle. No Secondary Lithium battery types shall be used for the Supplemental Battery

---

<sup>3</sup> The Battery Protection System is intended to be the last level of protection for the battery. Teams should implement soft limits where applicable to prevent faults of the Battery Protection System to minimize or eliminate the need to stop to investigate/restart during the event.

## **8.4 Battery Enclosures**

All registered and sealed battery modules, supplemental batteries, battery protection circuitry per Reg. 8.3, and main fuses per Reg. 8.5, must be fully contained in enclosures that are electrically isolated from the solar car. The inside of the enclosures must be a non-conductive material. No more than two separate such enclosures may be used for the main and supplemental batteries.

### **8.4.A Isolation**

The resistance measured between the battery terminals and any portion of the solar car chassis shall be greater than 1 M $\Omega$  for applied potentials up to 500 V.

### **8.4.B Mounting**

The battery enclosures must be secured to the solar car chassis so as to prevent them or the modules within from coming loose in the event of an accident or rollover. Nylon luggage type buckles are not acceptable means of securing the battery enclosure.

### **8.4.C Marking**

The top of each battery enclosure must be marked using letters at least 10mm high with "Caution: Chemical Hazard" and "High Voltage" and any other standard hazard markings specific to the type of battery enclosed. The type (i.e. Li-ion) of the battery must be marked on the top of the battery enclosures(s) in 10 mm high letters.

### **8.4.D Ventilation**

The battery enclosure(s) containing the main battery must be equipped with a forced ventilation system. It must operate whenever the battery system is enabled and the Main Power Switch is on. The ventilation system must pull air through the battery rather than push it – ie, the battery enclosure should be at negative (not positive) pressure relative to ambient pressure. The exhaust airflow must be directed through sealed ducting to the exterior of the solar car in a location away from any airstream that may reach the driver or occupant(s).

### **8.4.E External Cooling**

External supplementary cooling of the battery pack is not permitted beyond the ventilation requirements listed in Reg. 8.4.D unless the external cooling is powered by the main battery pack and is physically contained and secured to the solar car, or in an emergency situation.

### **8.4.F Security**

To preclude unauthorized access to the battery/enclosure, a seal will be placed to indicate contravention of this regulation. Provisions shall be made to seal the battery/enclosure by the team. Should access to a "sealed" battery/enclosure be needed, the team needs to inform an Official of their intent to access the battery/enclosure, and request the Official to log the activity and retain the seal. Battery exchanges will not occur during the Event without Inspector support.

## 8.5 Fusing

### 8.5.A Main

A DC-rated fuse (not a circuit breaker) must be placed first in series with the battery starting at the positive connection within each battery enclosure. Both leads to the fuse must be mechanically constrained to battery enclosure using a fuse block and cover. The fuse rating must not exceed 200% of the maximum expected current draw or 75% of the rated wire current capacity. It must be rated to break the Fault Current due to a shorted pack and protect the relay or switch. (High Speed or Fast Acting Semiconductor Type Fuse)

### 8.5.B Branch

All other wiring branching off the main bus circuit must have properly sized fuses. Fuses must be located near the branch point, either within the same enclosure or before a reduction in rated conductor ampacity.

### 8.5.C Voltage Taps

**8.5.C.1** When in the Safe State, residual current draw on any battery measurement tap shall be less than 10 mA.<sup>4</sup>

**8.5.C.2** When in the Safe State, any voltage tap leaving the battery box must be current limited to less than 10 mA.

## 8.6 Power Switch

### 8.6.A Main Power Switch

**8.6.A.1** Solar cars must be equipped with a Main Power Switch that is principally located within the main battery enclosure. The power switch must be normally open and non-latching.

**8.6.A.2** The solar car driver must have overriding control and the ability to turn the power switch off at all times.

**8.6.A.3** The power switch control location must be within easy reach of the driver and clearly labeled with the words "POWER", "ON" and "OFF". All letters must be 10 mm tall or larger.

**8.6.A.4** In the off position, the main power switch must isolate the high voltage battery, motor, and array from each other and put the solar car in the 'Safe State'. The high voltage battery pack isolation switches must be electrically located first in series after the battery negative terminal and second in series after the battery positive terminal with only the main fuse connected before it.

**8.6.A.5** The power switch must be DC rated and capable of interrupting an overcurrent condition.

**8.6.A.6** The BPS must have overriding control and the ability to turn the power switch off at all times in the event of a BPS fault.

### 8.6.B BPS Fault Dash Indication

The driver is to have an illuminated dash indication of a BPS fault to provide warning of an automatic opening of the Main Power Switch. This indicator must be labeled in text at least 5mm high and both the indicator and label must be within the driver's direct line of sight when the driver is seated in their normal driving position.

---

<sup>4</sup>Storage of batteries should include regular charging and removal of all parasitic loads to prevent battery damage

## 8.6.C External Power Cut Off Switch

For emergency use, a Main Power Switch control must be present on the exterior of the solar car. It must be possible to actuate the exterior Main Power Switch off with overriding control at all times.

**8.6.C.1 Location:** The switch location shall be on the solar car's exterior near the cockpit on the driver's side of the car. The switch must be on an upward-facing surface; it may not be placed on surfaces that are angled to such that the surface normal is pointing below the horizon.

**8.6.C.2 Operation:** Only "Push" switches are allowed. The actuator must be colored red, and at least 20mm in diameter (non-round pushbuttons must be large enough to fit an inscribed 20mm circle). Actuation of the external switch must also illuminate the BPS Fault indication including BPS Fault Dash Indicator. The switch shall be a latching type switch.

**8.6.C.3 Marking:** The external actuator must be clearly marked by the international marking of a red spark within a white-edged blue equilateral triangle with a minimum side length of 150 mm. In addition, clear directions how to operate the actuator must be displayed using letters 10 mm tall or larger.

**8.6.C.4 Covering:** The external actuator may be covered with a colorless transparent cover. Without the use of tools or significant force, it must be demonstrated that the actuator may be easily operated thru the cover. The cover must be labeled in such a manner as to how to operate the actuator thru the cover. The blue triangle marking may be located on the cover, but must not obstruct the view of the actuator.

## 8.7 Cables

### 8.7.A Cable Sizing

All electrical cables must be properly sized for expected system currents.

## 8.8 Control

### 8.8.A Sole Control

Any parameter that influences the safe and reliable operation of the vehicle must be under the sole control of the driver.

### 8.8.B Accelerator

Accelerator mechanisms on solar cars must be free moving, and when released, must return to the zero position. Should a pedal accelerator be used, it shall be mounted such that it is operated by the right foot and it shall be located to the driver's right of the brake pedal (if equipped).

### 8.8.C Cruise Control

If the solar car is equipped with cruise control, it can only be activated by the driver. The cruise control must be designed to automatically deactivate when the brake controls are manually actuated by the driver, or when the car is shut off.

### 8.8.D Reverse

The solar car must be able to be driven backwards under its own power with the driver seated in the normal position.

## 8.9 Electrical Shock Hazards

All exposed or easily exposed conductors, junction boxes, solar cells, etc., operating at greater than 32 V must be protected from inadvertent human contact and must be marked "High Voltage" in letters at least 10 mm high.

Exposed carbon fiber is conductive so care should be taken to ensure electrical components are isolated from it. Any covers allowing access into the enclosures must be firmly secured.

## 8.10 Impound

Battery enclosures shall be designed such that they can be Impounded per Reg 12.12.B. Enclosures may either be removed from the vehicle and placed in an impound box or impounded in the vehicle.

### 8.10.A Impound Box

Teams utilizing the impound box option shall provide an impound box that fully contains the battery enclosure(s) per Reg. 8.4 in such a way that completely restricts access to the battery box.

**8.10.A.1** The impound box must allow for an Official to secure it with a maximum of two (2) locks/seals.

**8.10.A.2** The impound box must be constructed such that it does not contain external hardware or hinge pins that can be removed to gain access to the battery box without breaking the seal(s).

**8.10.A.3** The top of the impound box must clearly be marked using at least 10 mm high letters with team number and university name.

### 8.10.B Impound In Vehicle

Teams utilizing the impound in vehicle option shall provide a robust impound solution that allows the event organizers to lock/seal any high voltage battery power connectors/conductors.

**8.10.B.1** The solution shall seal any main battery high voltage power connectors/conductors such that the team cannot charge the battery from external energy sources. This includes the battery box lid(s), and any other openings such as air inlets/outlets that could allow access to high voltage connections, as well as any power connections to the motor, solar array, etc.

**8.10.B.2** The solution shall have provisions such that an Official can secure it with a maximum of four (4) locks/seals used in the daily un-impound/impound process. Additional locks/seals may be applied during Scrutineering so long as they do not need to be broken every time the vehicle is impounded.

**8.10.B.3** The battery box shall be constructed such that it does not contain external hardware or hinge pins that can be removed to gain access to the battery box without breaking the seal(s).

### 8.10.C Impound Security Seal Marking

Each impound security seal location must be marked using 10 mm high letters with "Seal [#] of [total]". For example: "Seal 2 of 3".

## **8.11 Multi-Occupant Vehicle Charging and Metering**

### **8.11.A Charger**

MOVs must be equipped with a J1772 capable onboard vehicle charger that accepts external energy from a 120-240Vac power source and outputs DC power with an adjustable current limit to charge the main battery pack. The AC input side of the charger must include a safety ground connection from the vehicle power inlet and this must be tied to the charger/chassis if it contains any exposed metal. The charger must be rigidly secured in the vehicle in a location not susceptible to the ingress of water. The DC output of the charger must be electrically isolated from the AC input. The inputs and outputs on the charger must also be electrically isolated from the vehicle chassis.

### **8.11.B Vehicle Power Inlet**

MOVs must be equipped with a J1772 vehicle power inlet receptacle mounted and secured to the vehicle for delivering power to the onboard charger. The vehicle charging system must function in a manner that is compliant with the SAE J1772 automotive standard. This standard requires a communication handshake between the Electric Vehicle Supply Equipment (EVSE) and the onboard vehicle charger before charging can occur.

### **8.11.C Charging Adapter**

For MOVs designed for use in geographies with other standard EV connectors, an appropriate adapter may be used to go between a J1772 plug and a different vehicle power inlet receptacle. In this case, the charging adapter must be no longer than 1 m in length and must be carried in the MOV while not in use.

### **8.11.D Energy Metering**

Multi-Occupant vehicles will be required to carry an onboard AC energy meter provided by the Event Organizers – see details in Appendix L. The meter will have a wide measurement range for charging at 120-240Vac and up to 40A. The meter enclosure is a 6.7" x 10.63" x 4.33" box which must be installed inline between the J1772 vehicle power inlet and the AC input on the onboard vehicle charger. The energy meter box will feature a NEMA 14-50P plug input and a NEMA 14-50R output receptacle. The location of the meter in the vehicle must be such that its display can be read and teams must keep photo records with timestamps of the kWh meter reading at the beginning and end of each external energy charge.

The main battery box must provide a dedicated power port and a dedicated charger relay that is utilized only for external energy charging. All exposed connectors/conductors on the AC/DC charging power lines between this battery box port and the J1772 vehicle power inlet must be enclosed in an approved manner that can be locked/sealed by the Event Organizers to prevent any of these connections from being unplugged or tapped into to bypass the energy meter or the J1772 power inlet. The team must also provide a way to seal their charger such that unauthorized access to its internal components is prevented.

### **8.11.E Charging Safety**

Any covers for AC or DC power connections must be nonconductive and only removable with the use of tools. Such covers must be marked using 10 mm high letters with "Caution: High Voltage". Transparent covers that allow for visibility of connections are preferred. All conductors used for MOV charging must be appropriately sized to carry the vehicle's maximum possible charge current.

Charging from an external energy source is only allowed when the vehicle is stationary. When a J1772 plug is connected, the vehicle must automatically prevent the use of the drive motor(s).

When charging from an external energy source the BPS must always actively monitor the battery state. In case of a BPS fault condition where the Main Power Switches controlled by the BPS open, the output of the MOV charger must also disconnect from the battery pack. To minimize BPS faults, the onboard charger should curtail charging automatically when the main battery pack approaches a full charge.

### **8.11.F Electric Vehicle Supply Equipment (EVSE)**

Teams are responsible for providing their own Level 1/Level 2 SAE J1772 Electric Vehicle Supply Equipment to connect from an external energy source (utility grid, generator, etc.) to the vehicle power inlet. It is recommended for teams to bring adaptors that will allow them to charge from various North American power receptacles. The most common receptacle is the 120 Vac NEMA 5-15R but it is also recommended to have 240Vac adaptors available for faster charging from receptacles such as the NEMA 14-50R, NEMA 14-30R, NEMA 6-30R. Teams are not required to carry their J1772 Electric Vehicle Supply Equipment in the solar car.

**Note:** The Event Organizers are not responsible for providing external energy sources for MOV teams to use during the event or any adapters required to charge your vehicle. It is recommended that MOV teams have a generator available that could be used for charging the vehicle in the event that an acceptable alternate power source can't be identified.

### **8.11.G MOV Impound**

In impound configuration the metered J1772 vehicle power inlet must be the only functional power connection to the main battery pack. Failure to properly impound during the designated hours at the Event will result in a full unmetered external energy charge being added in the team's Score.

## 9. Solar Car Body

### 9.1 Solar Car Dimensions

The solar car (including solar collector) may not exceed the following maximum dimensions when moving under its own power:

- Length = 5.0 m
- Height = 1.6 m
- Width = 2.2 m

When turning corners, wheels and wheel fairings may exceed these dimensions.

### 9.2 Driving Configuration

While the vehicle is moving under its own power, reorientation and reconfiguration of wheel fairings and other aerodynamic devices is allowed, however, reorientation or tilting of the solar car body is prohibited.

### 9.3 Ground Clearance

When driving on a flat road, all parts of the fully laden solar car except the tires, wheels, and wheel hubs must be at least 100 mm above the ground.

### 9.4 Lighting

Solar cars must have lighting as outlined below.

All lights required in this regulation shall be at least as bright as the reference standard defined in Appendix C from 30 m away throughout the required viewing angles as defined below. Inspection for the viewing angles and light intensity can be conducted at any point within the defined distance and view angles. All positions are to the center of the light emitting portion of the light.

*Inspect your lights outdoors, in bright sunlight, at the prescribed distances and angles, PRIOR to arriving at the event! Lights that look great inside dim garage bays may be essentially invisible in real-world outdoor conditions.*

#### 9.4.A Daytime Running Lights

**9.4.A.1 Position:** shall be located at least 600 mm apart (at least 400 mm apart if the car is less than 1300 mm wide), at least 250 mm above the ground, and at a distance no further back than 200 mm from the absolute front of the vehicle.

**9.4.A.2 Color:** white

**9.4.A.3 Viewing Angle:** 10° upwards, 10° downwards, 20° outwards, and 20° inwards

**9.4.A.4 Operation:** The Daytime Running Lights shall operate whenever driving is possible (motor power is enabled). It is permissible to disable the running light while the co-located front turn indicator is in operation. The turn indicator has the priority in operation.

#### 9.4.B Front Turn Indicators

**9.4.B.1 Position:** shall be located at least 600 mm apart (at least 400 mm apart if the car is less than 1300 mm wide), at least 350 mm above the ground, and at a distance no further back than 175 mm from the absolute front of the vehicle.

**9.4.B.2** Shall flash between 60 and 120 pulses per minute

**9.4.B.3 Color:** amber

**9.4.B.4 Viewing Angle:** 80° from center in outwards, 45° from center in inwards (see Figure 1), 5° down, and 15° up from horizontal.

**9.4.B.5 Operation:** If the co-located Daytime Running Light is not disabled during turn indicator operation, the turn indicator shall be visible with the running light on.

#### 9.4.C Side Marker Turn Indicators

**9.4.C.1 Position:** shall be mounted on each side of the vehicle between 500 and 1800 mm rearward from the absolute front of the vehicle and within 400 mm of the extreme outer edge of the car.

**9.4.C.2** Shall flash between 60 and 120 pulses per minute

**9.4.C.3 Color:** amber

**9.4.C.4 Viewing Angle:** 5° down and 15° up from horizontal, horizontal visibility as shown in Figure 1:



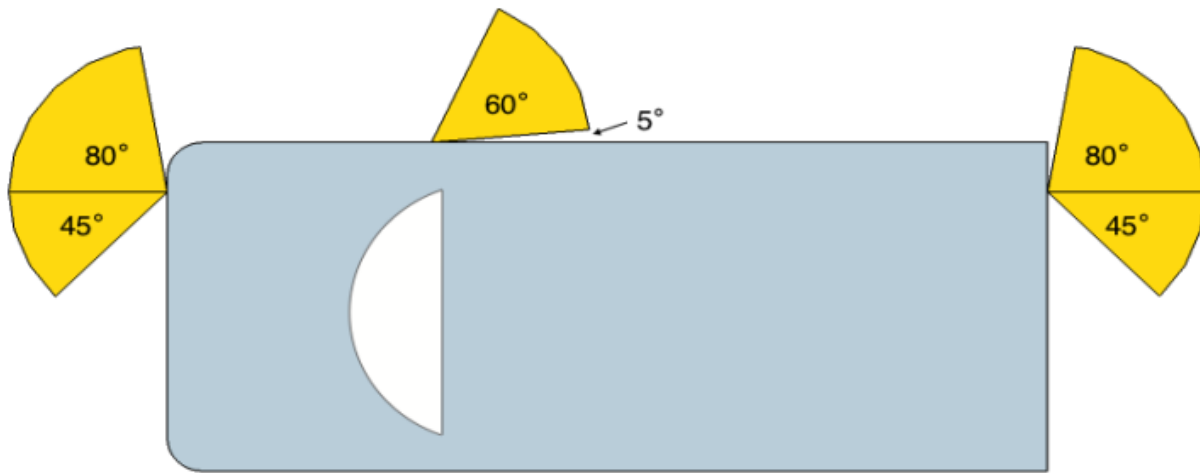


Figure 1: Turn Indicator Horizontal Visibility (for the right turn indicators)

#### 9.4.D Rear Brake Lights

**9.4.D.1 Position:** shall be located within 400 mm of the extreme outer edge of the car on each side, at least 600 mm apart (400 mm if the car is less than 1300 mm wide), at least 350 mm above the ground, and at a distance no further forward than 200 mm from the absolute rear of the vehicle.

**9.4.D.2** It is permissible to have one set of lights per side of the car which operate as both the brake lights and turn indicators. The turn indicator operation has the priority in operation.

**9.4.D.3 Color:** red

**9.4.D.4 Viewing Angle:** 45° from center outwards and inwards, 5° down, and 15° up from horizontal.

**9.4.D.5 Operation:** Brake lights should operate if and only if the driver presses the brake pedal or regenerative braking is active.

#### 9.4.E Rear Turn Indicators

**9.4.E.1 Position:** shall be located within 400 mm of the extreme outer edge of the car on each side, at least 600 mm apart (400 mm if the car is less than 1300 mm wide), at least 350 mm above the ground and at a distance no further forward than 200 mm from the absolute rear of the vehicle.

**9.4.E.2** It is permissible to have one set of lights per side of the car which operate as both the brake lights and turn indicators. The turn indicator operation has the priority in operation.

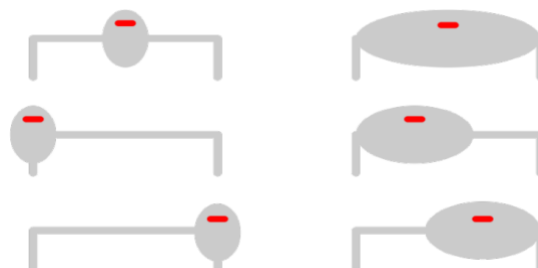
**9.4.E.3** Shall flash between 60 and 120 pulses per minute

**9.4.E.4 Color:** amber (if separately equipped from Rear Brake Lights)

**9.4.E.5 Viewing Angle:** 80° from center outwards, 45° from center inwards, 5° down, and 15° up from horizontal.

#### 9.4.F High Mounted Center Brake Light

**9.4.F.1 Position:** Viewed from behind the solar car, the lateral position of the light shall coincide with the visual center of the solar car (see the examples in the following diagram). The top of the lamp shall be less than 150mm below the highest point of the car, and the bottom of the lamp shall be higher than the top of the rear brake lights.



**9.4.F.2 Color:** red

**9.4.F.3 Viewing Angle:** 10° from center in both left and right, and 10° up and 5° down from horizontal.

## 9.4.G BPS Fault Indicator

**9.4.G.1 Position:** Located adjacent to the center brake light, see 9.4.F.1. May be on any side (left, right, top, or bottom) of the center brake light.

**9.4.G.2 Activation:** It is to activate any time the Battery Protection System (BPS) actuates to automatically open the Main Power Switch and remain active while the BPS fault is present. Shall also activate when the External Power Cutoff Switch is actuated (8.6.C.2). It shall not activate under any other conditions.

**9.4.G.3** Shall flash between 60 and 120 pulses per minute

**9.4.G.4 Color:** white strobe

**9.4.G.5 Viewing Angle:** 10° from center in both directions and 10° up from horizontal.

## 9.4.H Emergency Hazard

The front turn indicators, side marker turn indicators, and rear turn indicators shall be able to be activated simultaneously and flash in sync as an Emergency Hazard signal.

## 9.4.I Horn

Solar cars shall be equipped with a horn that can be heard at a sound power level between 75 and 102 dBA at a distance of 15 m in front of the solar car. The horn shall be permanently mounted, operated from the steering wheel, and shall be able to operate for up to 5 minutes continuously at the required volume.

## 9.5 Visibility

### 9.5.A Eye Height

In the normal driving position with a fully laden solar car, all occupant's eyes must be at least 700 mm above the ground.

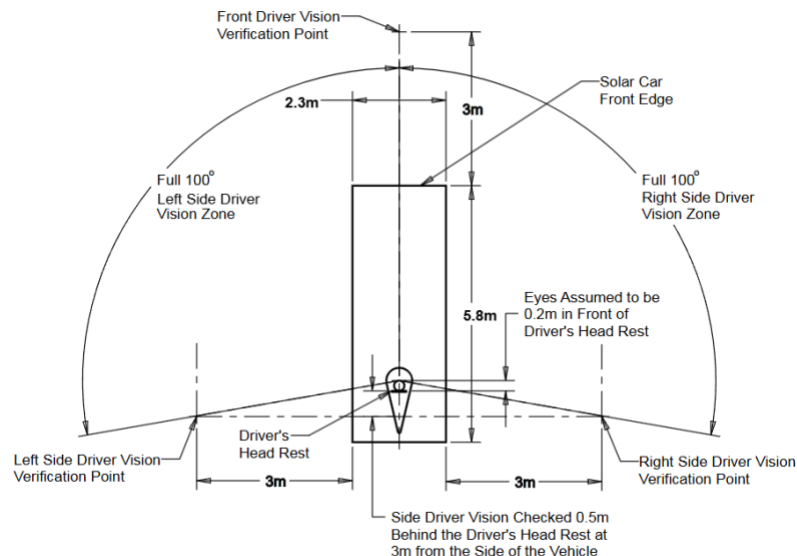
### 9.5.B Forward and Sideward Vision

From the normal driving position, the driver must be able to see at all times, without artificial assistance, points at the following locations:

**9.5.B.1** A point on the ground 8m ahead of the absolute front of the vehicle, aligned on the centerline of the solar car.

**9.5.B.2** A point 6.4 m above the ground and 12.2 m ahead of the absolute front of the vehicle, aligned on the centerline of the solar car. This may be inspected with an object lower and closer to the car in order to simulate this viewing angle.

**9.5.B.3** The driver will be required to identify 50mm high letters held about 1 m off the ground at the three verification points indicated in the image below. Spot checks may be made with these letters at distances 3m from the edge of the car throughout the entire left and right driver vision zones indicated. Some elements of the roll cage may obstruct a portion of these zones, however, the driver's view must be unobstructed as much as is reasonably possible by the solar car structure.



### **9.5.C Windshield**

- 9.5.C.1** All solar cars must have a windshield that is securely mounted to the solar car.
- 9.5.C.2** The windshield must be made of shatter-resistant material; the material must have a Notched Izod Impact Strength of at least 30 kJ/m<sup>2</sup> (ISO 180/1A) or 320 J/m (ASTM D256).
- 9.5.C.3** The windshield must be free of excessive distortion.
- 9.5.C.4** The windshield should not be tinted to the extent that the driver cannot be clearly observed from outside the solar car.
- 9.5.C.5** The solar car driver must be able to discern traffic light colors through the windshield.

### **9.5.D Rain Clearing**

- 9.5.D.1** Solar cars must have a method to clear the windshield from any falling rain such that the vision requirements of Reg. 9.5.B can be met.
- 9.5.D.2** The clearing method must be operable at all times and must be in use when it becomes necessary to use the windshield wipers on the team's support vehicles.
- 9.5.D.3** Hydrophobic coatings (such as Rain-X) are acceptable.

### **9.5.E Rear Vision**

- 9.5.E.1** All solar cars must be equipped with a rear-view system that at all times will allow the driver to see a vehicle 15 m directly behind the solar car and up to 30° off center. The system must provide the driver with a single reflex type image and must operate without driver input. The driver will be required to identify the direction of an arrow with a 200 mm thick brush stroke on a 1 m<sup>2</sup> board held about 1 m off the ground.
- 9.5.E.2** If equipped: the camera and view screen shall be fixed in position such that road bumps and vehicle vibration will not alter the viewing angles.
- 9.5.E.3** If equipped: the view screen shall be positioned such that the driver shall be able to see the view screen while seated in normal driving position.

### **9.5.F Outside Air Circulation**

Outside air, from intake vents and directed towards the occupant's face, must be provided. Should intake vents from the wheel openings be used, the natural air flow rate through the ducting to the occupant compartment shall be augmented by a ventilation fan.

## 9.6 Egress

### 9.6.A Performance Requirement

**9.6.A.1** Teams shall define primary and secondary directions for egress. The primary and secondary directions must be separated by at least 90 degrees and both primary and secondary directions cannot be on the same side of the solar car. For Multi-Occupant solar cars, the primary and secondary directions may be different for each occupant.

**9.6.A.2** For Single-Occupant solar cars, teams will be required to demonstrate that the occupant can exit the vehicle unassisted, standing clear of the plane of the car, in less than 10 seconds for the primary direction and less than 15 seconds for the secondary direction.

**9.6.A.3** For Multi-Occupant solar cars teams will be required to demonstrate that each occupant can exit the vehicle unassisted, standing clear of the plane of the car, in less than 10 seconds for the occupant's primary direction and less than 15 seconds for the occupant's secondary direction<sup>5</sup>. It is envisioned that during the testing the drivers and occupants will be tested at the same time.

**9.6.A.4** The solar car shall not be chocked during the egress test.

### 9.6.B Occupant Cockpit and Opening

**9.6.B.1** The occupant's cockpit must be designed to allow each occupant to exit the vehicle unassisted in two directions - reference Reg. 9.6.A.1.

**9.6.B.2** Occupant egress openings must be able to be secured and released from both the inside and outside of the vehicle. Such openings may not be sealed or secured with adhesive tape at any time.

**9.6.B.3** Occupant egress openings must be **positively latched closed** – Velcro, magnets, cabinet catches, and similar closure methods that do not positively retain the egress opening will not be allowed.

**9.6.B.4** The perimeter of the egress opening shall be clearly marked with a 25 mm wide stripe that is of a high contrast color.

**9.6.B.5** The external canopy release shall be marked with letters "OPEN" with a minimum height of 20 mm in the same high contrast color as the egress opening marking.

**9.6.B.6** The external canopy release shall be located within 300mm of the edge of the egress opening.

---

<sup>5</sup> It is envisioned that during Scrutineering the egress of the drivers and occupants will be tested at the same time. I.e. the driver (assumed to be at the front left position of the car) will egress in their primary side, (i.e. assumed to be the left front door), whereas the passenger (assumed to be at the front right position of the car) will egress to their secondary side (i.e. assumed to also be the left front door). This is intended to check egress for a scenario where the car is against an object on the right preventing egress in that direction.

## 9.7 Ballast

The official weight of each occupant, including clothes (including shoes, excluding helmet, with empty pockets), will be 80 kg. If an occupant weighs less than 80 kg, ballast will be added to make up the difference. If an occupant weighs more than 80 kg, no credit will be given.

### 9.7.A Ballast Bag

Each registered solar car occupant will be allowed one bag to contain their required ballast. This bag will be a single colored canvas bank (coin) bag provided by the Event Organizers with dimensions of 305 mm x 482.5 mm. Ballast must be able to be contained within the canvas bag allowing security seals to be applied. Consideration should be made to ensure that a full ballast bag will fit securely in the car's ballast box(es).

### 9.7.B Ballast Box

**9.7.B.1** Each solar car must have one (1) ballast box for each occupant.

**9.7.B.2** Each Ballast Box shall have a lid which is secured closed for carrying ballast. The Ballast Box(es) must be securely fastened to a structural member of the solar car and/or be demonstrated to hold the ballast fixed in the event of an impact.

**9.7.B.3** Each occupant's Ballast Box shall be located within a 300 mm horizontal distance of the occupant's hip location.

*As ballast may be several 10s of kilograms of mass, and you do not want this mass flying around inside the car unsecured in a crash, do not let your ballast box be an afterthought. Ballast boxes zip-tied to the chassis will not pass inspection.*

### 9.7.C Common Ballast

**9.7.C.1** Teams entered in the Single-Occupant class may elect to use a Common Ballast. The Common Ballast provision does not apply to drivers or passengers in MOVs.

**9.7.C.2** Should a team elect to use a Common Ballast, then each solar car driver shall have one (1) individual ballast bag and the Common Ballast bag. The sum of the two (2) ballast bags shall be equal or greater than the ballast required to bring the driver's weight up to 80 kg.

**9.7.C.3** Teams that plan to use a Common Ballast must equip their cars with a Common Ballast Box that complies with Reg. 9.7.B.2. This box may be located anywhere within the vehicle. The Common Ballast bag will be sealed within the Common Ballast Box at the start of the event.

### 9.7.D Ballast Access

Occupants and their corresponding ballast will be identified with unique identification tags. The tags on the ballast carried by the solar car must match the tags on the occupant at all times. The ballast bag and its identification and security markings must be visually accessible by the Inspectors during driver changes.

### 9.7.E Ballast Type

Teams will provide their own material for ballasting purposes. Ballast types allowed shall be either steel shot, lead shot, or coin. All other types of ballast will not be allowed. Consideration should be made with respect to the density of material selected and a driver's weight to ensure that the required ballast needed will fit into the bag provided.

## **9.8 Solar Car Markings**

### **9.8.A Team Numbers**

**9.8.A.1** Each team registered for the Event will have a unique number approved by Headquarters (positive integer, three (3) digits maximum).

**9.8.A.2** This number must be clearly displayed on both sides of the solar car and clearly visible from a distance of 3 m perpendicular to the side of the vehicle at a viewing height of 1.8 m above ground.

**9.8.A.3** Each number must have a minimum of 50 mm of unobstructed background color on all sides. These colors can be black on white, white on black, or another high-contrast color approved by Headquarters. The numerals themselves must be a minimum of 250 mm high, 120 mm wide (except the numeral one), and have a minimum brush stroke of 40 mm. Numbers containing more than one digit must have a minimum of 25 mm spacing between the digits.

### **9.8.B Institution Name(s) & Sponsors**

**9.8.B.1** The name of the Institution(s) hosting the team must be clearly displayed on both sides of the solar car and clearly visible from a distance of 3 m perpendicular to the side of the vehicle at a viewing height of 1.8 m above ground.

**9.8.B.2** Headquarters must approve the use of abbreviations or initials. The Institution's name shall be larger and more prominent than any team sponsor name/logo. Additional graphics related to a team's institution(s) or sponsors are permitted, provided they are neither offensive nor disruptive.

### **9.8.C Event Logo**

**9.8.C.1** The Event logo shall be clearly displayed on both sides of the solar car and clearly visible from a distance of 3 m perpendicular to the side of the vehicle at a viewing height of 1.8 m above ground.

**9.8.C.2** The logo will be provided by Headquarters and will measure no more than 200 mm in height by 500 mm in width.

### **9.8.D National Flag**

**9.8.D.1** The national flag of the country of the team must be displayed on both sides of the solar car adjacent to the windscreen and clearly visible from a distance of 3 m perpendicular to the side of the vehicle at a viewing height of 1.8 m above ground.

**9.8.D.2** The minimum size of the flag is 70 mm by 40 mm.

### **9.8.E Front Signage**

**9.8.E.1** Solar cars must have an unbroken front signage area on the solar car body, forward of the windscreen. The entire front signage area must be visible in top view and in front elevation view and must not overlap the solar collector.

**9.8.E.2** A 150 mm x 150 mm Event logo must be placed within the front signage area. The logo will be provided by Headquarters.

**9.8.E.3** The front signage area should also include the name of the Institution(s) hosting the team.

## 10. Mechanical

### 10.1 Body Panels

All moving or removable body panels and the array must be securely fastened to prevent unintended movement.

#### 10.1.A Covers and Shields

All moving parts must be suitably covered to prevent accidental human contact when the solar car is fully assembled. The driver must be shielded from contact with all steering linkage and other moving parts.

#### 10.1.B Clearance

Interference or rubbing of the wheels with the solar car's body, wheel well, or structure at full steering lock or suspension travel is not permitted. Movement of rod-end bearings may not be obstructed in any axis throughout the full travel of suspension and steering. Other moving parts, such as the motor shaft, must not contact stationary parts except through properly designed bearings. All wheels and their suspensions, steering linkages and geometries will be inspected for safe operation in normal and adverse conditions.

#### 10.1.C Array Attachment

Teams shall provide two independent and different means of securing the solar collector (top shell of the car) to the chassis. The two independent and different methods requirement is meant to provide additional reliability. The two methods could be for example 1) perimeter locking and 2) back-up lanyard.

If lanyards are used as one of the methods, the lanyards and the hardpoints on both the solar collector and chassis shall be capable of holding a 900 N (202 lbf) load. The lanyards shall not allow more than 600mm of upward travel of the solar collector. The forward hardpoint in both the solar collector and chassis shall be within 300mm of the forwardmost point of the seam that splits the collector portion from the chassis. The second hardpoint shall be behind the driver and on the opposite side of the vehicle centerline from the forward hardpoint.

Zip ties or tape are not allowed methods of array attachment. Tape can be used for aerodynamic sealing but shall not count as an attachment method.

### 10.2 Tire and Wheel Requirements

#### 10.2.A Wheel Configuration

**10.2.A.1** Single-Occupant class vehicles shall have at least three (3) wheels. Multi-Occupant class vehicles shall have at least four (4) wheels. All tires shall be in contact with the ground at all times.

**10.2.A.2** The distance between the left wheel contact patches and the right wheel contact patches shall not be less than half the width of the solar car (at its widest point).

#### 10.2.B Design Intent

The wheels and tires shall be designed for the intended application and able to withstand the loads and forces imparted by the vehicle's mass, speed capability, and braking potential. Each wheel and tire on a single axle shall be rated for the full weight applied to that axle.

#### 10.2.C Static Stability

The fully laden solar car shall not tip when tilted by 45° about each pair of adjacent tire contact patches.

## 10.2.D Tires

**10.2.D.1** Solar cars shall be fitted with tires that are compliant with US DOT standards, UNECE Regulation 30 or UNECE Regulation 75, as indicated by a DOT or E approval marking on the tire.

**10.2.D.2** Tires shall be loaded and inflated within the manufacturer's rating at all times during vehicle operation.

**10.2.D.3** If the tire is deemed to be a tube-type tire as per the manufacturer's specification, the appropriate tire tubes shall be used.

**10.2.D.4** The speed rating of the tires shall be more than the maximum speed of the solar car. If not, the solar car will be speed limited to the rating of the tire.

**10.2.D.5** The load rating of the tire shall be more than the maximum static load imposed by the fully-laden solar car.

**10.2.D.6** The tires shall be free of any apparent defect.

## 10.2.E Wheels/Rims

The rim profile shall be shown that it is in accordance with (or matches) the bead requirements of the tire as specified by the tire manufacturer.

## 10.3 Cockpit

The cockpit may not subject the solar car occupants to excessive strain during normal operation, and must be designed to protect the occupants from injury in the event of an accident. The occupants must be provided adequate space for safe operation of the vehicle. Care needs to be taken in the design and construction of the vehicle to minimize the risk that any shafts or sharp objects could penetrate the cockpit in the event of a crash and potentially injure the occupants.

### 10.3.A Occupant Cell

**10.3.A.1 Roll Cage:** is the structural cage that encompasses the occupants from the level of the top of the shoulders upward. Any structure above the shoulder is considered to be part of the roll cage.

**10.3.A.2 Structural Chassis:** is the tubular frame / monocoque composite chassis / hybrid of composite & tubular frame which encompasses the occupant's bodies, and to which the vehicle suspension system is connected.

**10.3.A.3** All solar cars must be equipped with a roll cage that is fixed and integrally connected to the structural chassis.

**10.3.A.4** The roll cage shall be constructed with metal elements. Composite roll cages are not permitted.

**10.3.A.5** The portion of the structural chassis surrounding the driver below the roll cage shall be referred to as the Lower Occupant Cell.

**10.3.A.6** The combination of the solar car Lower Occupant Cell and Roll Cage comprises the Occupant Cell.

**10.3.A.7** Teams must provide documentation that specifies which parts of their solar car constitute the Occupant Cell.

**10.3.A.8** The Occupant Cell shall encompass the occupant in all directions. When occupants are seated normally, with safety-belts and helmets on, no part of any occupant, nor the full free range of motion of the occupant's head (including helmet), may pass through planes drawn between the outer edges of adjacent tubes of the Roll Cage or Lower Occupant Cell, OR may intersect a line drawn between any two points on the outside-facing edge of adjacent tubes of the Roll Cage or Lower Occupant Cell.

*Imagine stretching a rubber skin around the Occupant Cell in a manner that it is in contact with the full length of every external tube; no part of any occupant or their helmet may touch the skin when fully buckled into the seat.*

**10.3.A.9** Each team must provide calculations, certified by the team's certifying reviewer, to show that the Roll Cage will not yield and all other components of the Occupant Cell will not deform by more than 25 mm and will not fail (exceed ultimate strength) at any point when subjected to the load cases outlined in Appendix F, section F.3.3, where  $g$  is the total gross mass of the vehicle including all occupants and ballast as submitted in the Mechanical PVDR Form (Appendix E).

**10.3.A.10** The protection provided for the occupants in a collision must be documented in the team's Mechanical Vehicle Design Report as per Reg. 5.2.B.



**10.3.A.11** A preliminary sketch and description of the Occupant Cell must be submitted in the Preliminary Vehicle Design Report by the date indicated in Reg. 4.3.A.1, as per Reg. 5.1.A.

**10.3.A.12** In addition to providing collision and rollover protection, the roll cage must be designed so as to deflect body/array panels of the car up and away from the occupants in the event of an accident. The front roll cage shall be angled backwards to facilitate deflection of the body/array panel. When occupants are seated normally, with safety-belts and helmets on, the full free range of motion of the occupant's head (including helmet) shall not be able to protrude from the front of the roll cage.

**10.3.A.13** Wherever the Occupant Cell may come in contact with an occupant's helmet, the roll cage or structure must be padded with energy-absorbing material meeting SFI-45.1 or FIA 8857-2001 Type A or B, or better. This material must be bonded and secured to the structure, wrapping around 50% of the roll cage member or piece of vehicle structure.

**10.3.A.14** A head restraint of at least 19 mm thick resilient material must be securely mounted behind the occupant's head without the use of cable ties, fabric straps, or temporary attachments. The headrest must support the occupant's head in normal driving position.

**10.3.A.15** There must be 50 mm of clearance in all directions between any member of the Occupant Cell and the helmets of the occupants seated in the normal driving position. There must be at least 30 mm of clearance between the occupant's helmet and the padding to allow for free movement of the occupant's head.

**10.3.A.16** Any carbon fiber panels rigidly attached to the Occupant Cell within 500 mm of the center of an occupant's head in a normal seated position and above the top of the occupant's shoulders shall have shatter resistant fabric (such as Kevlar or Dyneema) applied to the interior surface of the panel. The layer or layers shall total at least 5 oz/yd<sup>2</sup> of fabric weight.

*In this context, "rigidly attached" includes any panel that is part of the occupant cell structure, or bolted or bonded to the Occupant Cell. This does not include panels that are part of a removable top shell held on by an array attachment system as described in 10.1.C. This regulation in no way allows for composite roll cages. It addresses composites that are not part of the Occupant Cell structure, but near the occupant's head or neck, as well as Occupant Cell panels below the shoulder, but near the driver's head or neck. The protection layers should have the minimum feasible number of cuts or breaks needed to conform to surface curvature.*

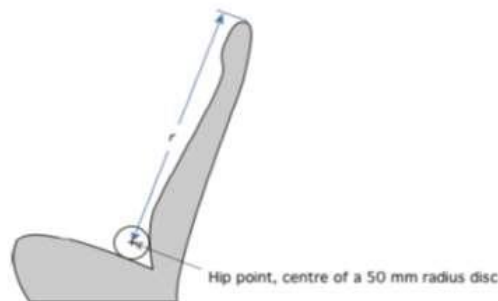
## 10.3.B Occupant Seats

**10.3.B.1** Single-Occupant solar cars shall be designed for 1 occupant with only one seat.

**10.3.B.2** Multi-Occupant solar cars shall be designed for 2 to 4 occupants with a seat for each occupant.

**10.3.B.3** Each solar car occupant must have a seat that faces forward at an angle less than 10 degrees of yaw from the forward direction of travel.

**10.3.B.4** Each seat must have a back and a head restraint per Reg. 10.3.A.14. The distance from the hip point to the top of the head restraint must be at least 800 mm for front seats and those of a single-occupant solar car and at least 750 mm for rear seats. (49 CFR 571.202a - Standard No. 202a; Head restraints). The hip point may be approximated as shown in the diagram below. Any additional seat padding must be included in this measurement.



**Figure 2 Hip Point Definition**

**10.3.B.5** Each occupant's heels must be below their hip point.

**10.3.B.6** The angle between each occupant's shoulders, hips and knees must be more than 90 degrees.

**10.3.B.7** Any additional seat padding must be positively secured to the seat.

### 10.3.C Occupant Space

**10.3.C.1** The occupant space for each occupant's upper torso shall be defined by an arc defined with an 835 mm radius measured from the hip point as defined in Appendix B of the occupant and projects forward 45 degrees from vertical, 25 degrees rearwards and 7 degrees side-to-side from the centerline of the occupant<sup>6</sup>.

**10.3.C.2** The solar car structure, including the windshield must lie wholly outside the occupant space. The steering wheel, mirrors, seat backs, and head restraints may be inside the occupant space but must be designed to minimize the risk of injury to the occupant.

**10.3.C.3** The driver's head must be above and behind the driver's feet. The seat must be appropriately constructed with a solid base and back rest.

### 10.3.D Belly Pan

The cockpit must be equipped with a full belly pan to isolate the occupants from the road. The belly pan must be strong enough to support the full weight of each occupant. Each occupant's torso and limbs must be above the lower element of the structural chassis.

### 10.3.E Safety Belts

**10.3.E.1** All solar cars must be equipped with a minimum of a 5-point lap and shoulder belt harness system for each occupant.

**10.3.E.2** The use of safety belts is mandatory.

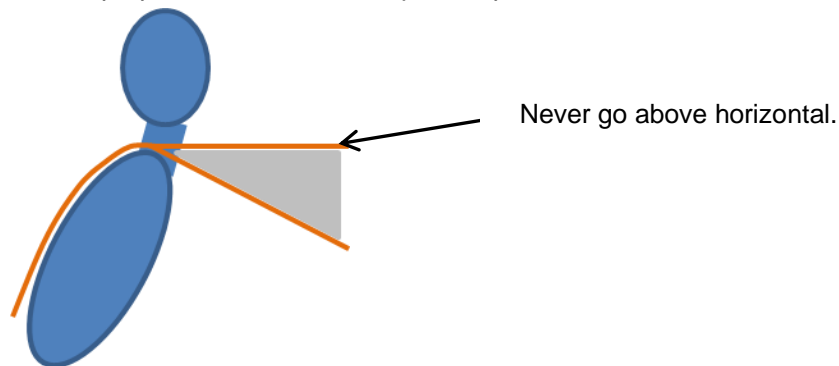
**10.3.E.3** The safety belts must be installed and attached securely to the structural chassis, as recommended by the manufacturer. Safety belt mounts should be designed to resist the same impact loads that the safety cell is designed for (Reg. 10.3.A.9)

**10.3.E.4** If the belt passes through the seat, it must pass through without wrinkling, crimping or bending the belt excessively. All sharp edges shall be removed or covered to prevent cutting or fraying of the belt.

**10.3.E.5** Only safety belt systems manufactured and certified to FIA 8853/98, FIA 8853-2016, SFI 16.1, SFI 16.5, or SFI 16.6 are allowed. Any modifications must be approved by the manufacturer.

**10.3.E.6** The placement of the attachment points for the seat belt harness shall be as follows (unless otherwise specified by the manufacturer):

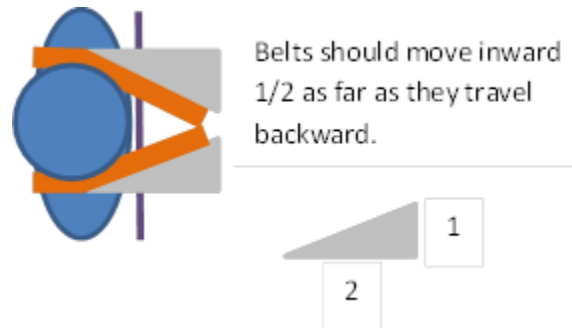
**10.3.E.7** The shoulder straps attachment point shall be rearwards between horizontal and highest of 30 degrees below horizontal and perpendicular to the occupant's spine or seat back



**Figure 10.2 Range of shoulder strap attachment position**

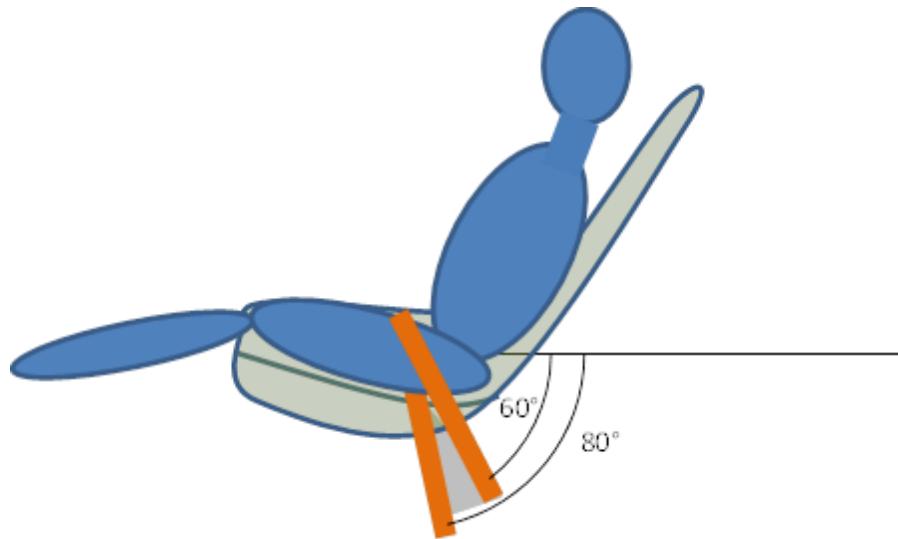
<sup>6</sup> This minimum occupant space requirement is based on a 50-percentile male and does not allow for a helmet. Taller team members may need more occupant space.

**10.3.E.8** The shoulder belts shall be spaced wide enough apart to not squeeze on the neck, but narrowly enough that they will not fall off the shoulders. The mounting points shall extend backward and go inward by approximately one unit for every two units that the mounting point is located behind the point that the belt leaves the shoulder.



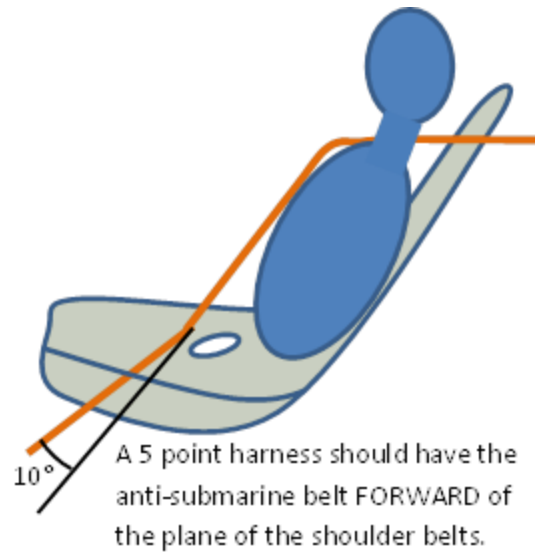
**Figure 10.3** Horizontal configuration of shoulder strap attachment

**10.3.E.9** The lap belt attachment point shall be downwards and rearwards from the occupant's lap between 60 degrees and 80 degrees from horizontal. The ends of the belt need to be well below the lap of the driver.

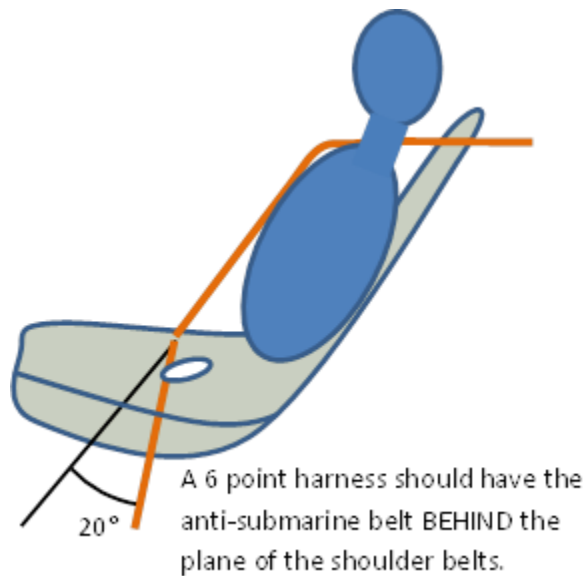


**Figure 10.4** Configuration of lap belt attachment

**10.3.E.10** The anti-submarine belt attachment shall be approximately 10 degrees forward of plane of shoulder belts for 5-point or approximately 20 degrees rearward of plane of shoulder belts for 6-point belts.



**Figure 10.5a Configuration of anti-submarine belt attachment (5-point harness)**



**Figure 10.5b Configuration of anti-submarine belt attachment (6-point harness)**

## 10.4 Fasteners<sup>7</sup>

All fasteners must be of suitable type, strength, and durability for their application. Friction, glued, or press fit assemblies will not be accepted in critical areas as the sole means of retention. For glued or press fit assemblies, a pin is required. The pin diameter shall be  $\frac{1}{4}$  of the tube's outer diameter. A press fit roll pin is acceptable for this application. Set screws intended to transmit torque or force will not be accepted. Fasteners must meet the following minimum requirements:

### 10.4.A Bolts

Bolts used in critical areas must at minimum meet SAE grade 5, metric grade M8.8 and/or AN/MS specifications. Bolts must be of the correct length, and extend at least two threads beyond the nut. Bolts in tension must not have shaved or cut heads. All fasteners should be properly torqued. U-bolts are not allowed in critical areas.

### 10.4.B Securing of Fasteners

All structural and other critical fasteners (bolts, nuts) must have an acceptable form of securing such that the fastener cannot loosen or be removed unintentionally. Acceptable methods of securing are:

- (1) Bolts with flex-loc type nuts or other nuts that use flexure as the means of locking and are re-useable.
- (2) Bolts with pre-drilled shafts and castle nuts with cotter pins installed to prevent loosening
- (3) Bolts with pre-drilled heads and/or nuts properly safety wired with stainless steel wire from 0.024" (0.6 mm) to 0.032" (0.8 mm) diameter conforming to Mil Spec MS20995C. The safety wire between fasteners and anchor points must be twisted to prevent loosening rotation of the fastener.
- (4) In blind hole applications, bolts with pre-drilled heads properly safety wired.
- (5) Other methods of securing fasteners may be deemed acceptable at the discretion of the Inspector.

Securing methods that are not acceptable are Nylon lock nuts, "lock" washers, Loctite, or lock nuts that use thread distortion as a means to secure the nut. Lock nuts with thread distortion are not considered to be re-usable. Other methods of securing fasteners where the above methods are not appropriate may be considered at the discretion of the Inspector. Non-critical fasteners need not be secured with lock nuts.

### 10.4.C Securing Rod Ends

All rod ends shall be secured with jam nuts tightened with sufficient torque to prevent rotation. The jam nuts on rod ends do not need to be safety wired or do not need to be flex-loc type of nut.

### 10.4.D Buckles and Straps

Plastic luggage type buckles or single push release straps are not considered acceptable means of securing any Critical Area. If nylon type straps are used in securing any Critical Area, ratchet type straps (without hook terminators) shall be used.

### 10.4.E Critical Areas

For application of the above critical areas are defined to include: steering, braking, suspension, seat mounts, safety harness, drive train, battery box, ballast box, and parking brake.

**10.4.E.1** Brake caliper systems present unique challenges to securing of fasteners. Teams should contact the inspectors prior to the event with any unique securing situations. Caliper securing will be evaluated in terms of total system redundancy.

### 10.4.F Hub Nuts

For designs using a single central hub nut to secure the wheel to the axle, the threaded portion of the hub nut shall be at least 10.9 mm thick.

---

<sup>7</sup> Fasteners are a complex subject and much care should be taken to choose appropriate fasteners for each application. Excellent references on proper use and securing of bolts can be found:

Smith, Carrol. Prepare to Win.

Reithmaier, Larry. Standard Aircraft Handbook.

Federal Aviation Administration. FAA Advisory Circular AC43-13-1B. Chapter 7 (securing of fasteners)

FAA-H-8083-30A. Aviation Maintenance Technician Handbook – General. pages 7-76 to 7-81

## 10.5 Brakes<sup>8</sup>

### 10.5.A Configuration

Solar cars must have a dual, balanced braking system so that if one system should fail, the solar car can still be stopped. The two systems must be operationally independent and must operate from a single foot pedal. The braking system can be front/rear or redundant front. Left/right redundancy is not permitted. Hydraulic systems must have separate master cylinders. Regenerative brakes may not be considered as one of the braking systems.

### 10.5.B Brake Pads

Each brake pad used in the braking systems must have a contact area with the brake disk that is greater than 6.0 cm<sup>2</sup>, and the pad must have full contact with the brake rotor. Pads must initially be at least 6 mm thick including the backing plate when installed on the car.

### 10.5.C Braking Performance

Solar cars must be able to repeatedly stop from speeds of 50 km/h (31 mph) or greater, with an average deceleration, on level wetted pavement, exceeding 4.72 m/s<sup>2</sup>. Performance shall be demonstrated with mechanical braking only (no regenerative braking will be allowed during the test).

### 10.5.D Brake Lines/Cables

The brake lines (hydraulic or cable) shall be appropriately sized and constructed such that they have significant capacity beyond the pressure and/or loads that will occur under the worst-case driving conditions.

### 10.5.E Pedal Position

Left foot brake pedal actuation is allowed. If the team elects to have both accelerator and brake pedals operated by the right foot, the team must demonstrate the pedal arrangement allows for the foot to rapidly transition between pedals. Refer to Reg. 8.8.B for placement of the accelerator pedal if equipped.

### 10.5.F Hand Activated Brakes

Hand activated brakes are permissible if the driver can turn the steering wheel lock-to-lock without removing or repositioning either hand from the steering wheel.

### 10.5.G Cars with Mechanical Rear Brake

**10.5.G.1** For solar cars without anti-lock brakes, the front wheels must lock-up before the rear wheels.

**10.5.G.2 Performance:** Cars with mechanical rear brakes as one of their primary brake systems shall be able to demonstrate that the rear brake can hold the car in place (front wheels elevated off the ground) on dry pavement under a forward pull equal to 15% of the cars weight in Track configuration with properly ballasted driver in place.

**10.5.G.3 Volume Limiting Valve-System:** cars with mechanical rear brakes with proportioning valves will require a means to lock-out the proportioning valve setting. The proportioning valve shall be positioned out of any occupant's reach.

---

<sup>8</sup> Braking systems for solar cars should be designed in accordance with standard automotive engineering practice. In general, bicycle type brakes are deemed to be too fragile for this kind of application and will not pass Scrutineering. This includes mountain bike type disc brakes. While such brakes may have enough stopping power to slow down a solar car, over long periods of application descending hills common in the ASC routes, they do not have appropriate levels of brake energy dissipation. Larger pads with more contact area can help ensure that vehicle braking systems are designed to dissipate heat to prevent failures involving boiling brake fluid, disc warpage, and loss of braking force. Vehicles that do not heed these recommendations may not pass Scrutineering or be allowed to compete.

## 10.6 Parking Brake

Solar cars must be equipped with a parking brake.

### 10.6.A Performance

The parking brake shall be able to hold the car in place without wheel chocks on dry pavement under either a forward or rearward force equal to 10% of the cars weight in fully loaded condition.

### 10.6.B Independence

This brake must operate completely independently from the main braking system and may not be used in the performance tests specified in Reg.10.9.D.

### 10.6.C Locking

**10.6.C.1** It must be able to be locked into the “ON” position, such that the driver does not have to continue to hold it to maintain position.

**10.6.C.2** The driver shall be able to set and lock the parking brake while seated in the normal driving position and seat belted in.

**10.6.C.3** The driver shall be able to set and lock the parking brake in a single action or motion.

**10.6.C.4** The parking brake shall not disengage without explicit driver input.

*Electrically operated parking brakes shall not disengage due to electrical faults such as loss of power.*

### 10.6.D Contact Style

The parking brake shall not be of a tire or wheel contact style (i.e. pad on tire or pad on rim styles are not considered as acceptable designs).

## 10.7 Steering

### 10.7.A Steering Wheel

All steering in the vehicle must be controlled by the driver with a steering wheel designed to have a continuous perimeter as outlined in Appendix A. The steering wheel must be sufficiently strong to withstand loads the driver may impose on it.

*Steering wheels 3D printed on hobby-grade FDM printers are extremely unlikely to pass inspection*

### 10.7.B Steering Stops

The steering system must include steering stops to prevent dangerous or damaging steering travel. Steering stops cannot be held in place by friction. They must be welded, pinned or bolted in place, and placed in the steering system in way that will not create loads that will deform or scar the contacting pieces.

### 10.7.C Turning Radius

Solar cars must be able to make a U-turn in either direction, without backing up, such that any portion of the solar car that is within 200 mm of the ground remain within a 16 m wide lane. Portions of the solar car above 200 mm above ground may exceed the 16 m distance.

### 10.7.D Steering Backlash

The steering system must be designed with sufficient strength/stiffness and have minimal backlash so that the driver can always maintain good directional control of the vehicle.

## 10.8 Towing Hardpoint

Solar cars must be equipped with a hardpoint where an appropriate rope or strap may be attached in order to tow the car for emergency recovery purposes. The hardpoint must be either securely attached to or part of a non-moving structural component such that the car can be towed in the forward direction. The hardpoint or access to the hardpoint may be covered while not in use. The hardpoint must allow the car to be pulled with the body installed on the car; however, the canopy may be removed.

## 10.9 Dynamic Stability

Solar cars will be tested for dynamic stability and handling performance. A combination of the following tests may be conducted:

### 10.9.A Figure-8

Solar cars must be able to negotiate a Figure-8 course in less than 8 seconds per side. The Figure-8 course shall have a 5 m wide lane around two (2) 6 m radius center circles, as illustrated in Figure 3. The vehicle shall not knock over any of the cones or exhibit signs of structural instability. No body work shall contact moving structural members per Reg. 10.1.B.

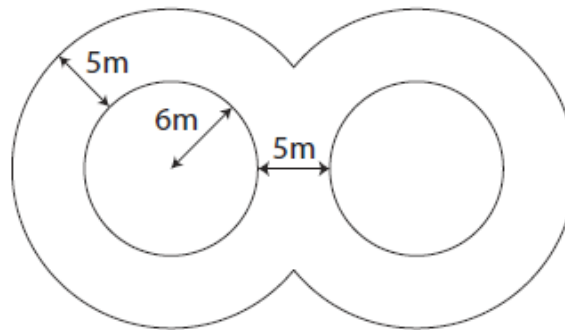


Figure 3 Figure-8 Course Layout

### 10.9.B Stability at Speed

**10.9.B.1** Solar cars must be able to stay within a 3.5 m lane for at least 250 m. Cars must be able to achieve this regardless of crosswinds or gusting conditions. If a car cannot do this at 104.6 km/h (65 mph), the car speed will be limited to where it can stay within a 3.5 m lane for the entire Event.

**10.9.B.2** If a team is observed to deviate from a lane three times during the Event, the maximum car speed will be limited to 16 km/h (10 mph) less than the recorded speed of the second lowest deviation, with a lower limit of 56 km/h (35 mph).

*Examples: If a team is observed to deviate from their lane at 51, 55, and 59 mph, their speed will be limited to 45 mph. If a team deviates at 41, 41, and 45 mph, they will be limited to 35 mph*

**10.9.B.3** If a team has had their speed limited per 10.9.B.2 and is observed to deviate from the lane again, their speed limit shall be limited to 16 km/h (10 mph) less than the recorded speed of the deviation with a lower limit of 56 km/h (35 mph).

**10.9.B.4** If a team has had their speed limited to 56 km/h (35 mph) and is observed to deviate from the lane, the car shall be disqualified until modifications are made to decrease instability and the vehicle is re-inspected by the Inspectors.

### 10.9.C Slalom Test

Solar cars must be able to negotiate a slalom course in 11.5 seconds or less. The slalom course shall be 126 m long, with cones equally spaced every 18 m as in Figure 4.

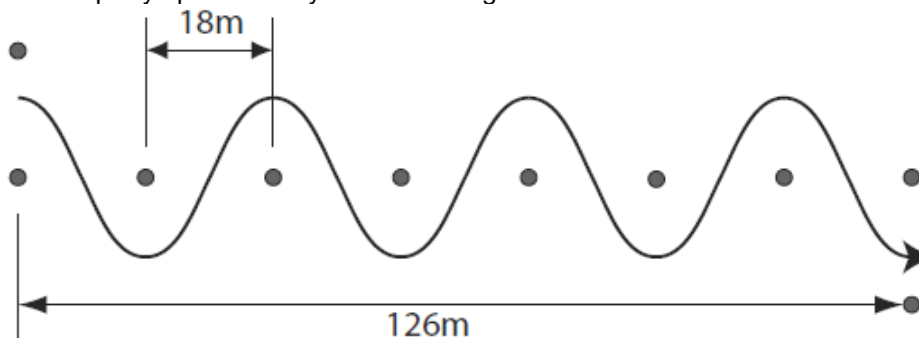


Figure 4 Slalom Course Layout



### **10.9.D Brake Test**

Solar cars will be tested to verify compliance with Reg. 10.5.C (Braking Performance). The time interval over which the deceleration is averaged shall be from the first indication that the driver should stop until the solar car comes to a complete halt. When braking, the solar car must not veer excessively to the left or right, or exhibit structural instability. The tire pressure and mechanical systems settings used in this test will be considered as the driving configuration.

**10.9.D.1** Solar cars may be required to demonstrate the brake performance a minimum of two (2) out of three (3) times.

### **10.9.E Acceleration Test**

Solar cars will be required to accelerate from a standing start and time will be recorded at a distance of 18m from the start line. Data will be recorded at FSGP 2025, and a lower allowable limit will be set in the ASC 2026 regs. This test is a proxy for vehicle torque/hill climbing ability.

### **10.9.F Disqualification of a Driver**

Should it become apparent to the Officials that the solar car is capable of passing the required dynamic stability requirements, but a driver is not able to proficiently handle the solar car during one or more of the required components, the solar car driver may be disqualified at the discretion of the Officials.

# 11. Occupant Requirements

## 11.1 Occupant Registration

All solar car occupants (drivers and passengers) must be registered at scrutineering. All occupants must be 18 years old or older.

### 11.1.A Drivers

**11.1.A.1** Only registered solar car drivers will be allowed to drive solar cars during the Event.

**11.1.A.2** Each team shall have a minimum of two (2) drivers available at all times and may register at most four (4) drivers.

**11.1.A.3** All drivers must have a valid, non-expired driver's license. A copy of their driver's license must be submitted with the team registration packet before Scrutineering (See Reg. 4.2.B)

**11.1.A.4** The solar car driver must be in the solar car during operation of the car.

### 11.1.B Passengers

**11.1.B.1** Drivers are eligible as solar car passengers. Teams may register at most eight (8) additional solar car passengers.

**11.1.B.2** The maximum number of occupants in a Multi-Occupant solar car shall be equal to the number of seats and seat belts provided.

## 11.2 Helmets

All solar car occupants must wear a helmet while operating the solar car. The helmet must meet or exceed the Snell M2010, Snell M2015 or Snell M2020, DOT FMVSS, ECE 22.05, AS/NZS 1698, or equivalent international motorcycle standards and will be inspected during Scrutineering.

## 11.3 Shoes

All solar car occupants must wear closed-toe shoes with a solid sole that will protect the occupant from debris that may be found on the road in the event of an accident in the solar car. Shoes with individually enclosed toes will not be permitted. Shoes that are securely fastened to an occupant's foot are preferred to avoid unintentional removal when driving or egressing the solar car. Occupant's shoes shall be approved at the Inspectors discretion.

## 11.4 Duration in Car

Each occupant may not be in the solar car more than a cumulative total of six (6) hours in a given Event Day. If the solar car is stopped on the side of the road such that the occupant is allowed to exit the vehicle for an extended period of time, this stopped time is not counted towards the six (6) hours driving time.

*This applies regardless of role in the solar car. For instance, if an occupant drives the solar car for five (5) hours in a day, they may only remain in the solar car as a passenger for one (1) additional hour during that day.*

## 11.5 Water/Fluids

Each occupant must have sufficient quantities of water/fluids in the cockpit area to stay properly hydrated. A minimum of two liters for each occupant must be provided.

## 11.6 Driver Communication

### 11.6.A Driver Communications

The solar car driver must have access to verbal and hands-free communication at all times with another team member outside the vehicle who is monitoring the solar car. Hands-free operation is defined as operation where the driver can activate the radio without removing their hands from the steering wheel.

If voice communication systems utilize volume detection rather than a push-to-talk button to initiate transmission, the communication system must be full-duplex.

## **11.6.B Cell Phone Use**

**11.6.B.1** Cell phones are permitted within the solar car. Any use of a cell phone by the solar car driver will need to be on a hands-free basis. Use of cell phone must comply with all local laws pertaining to cell phone use within a vehicle. Any cell phone must be fixed in position (i.e. not loose within the driver compartment).

**11.6.B.2** See 12.5 for cell phone use on FSGP

## **11.6.C Solar Vehicle Driver Communication**

For both Single and Multi-Occupant vehicles, the driver of the solar car must be in communication with the team's timers and pit area.

## **SECTION 3 – OPERATIONS**

## 12. FSGP Operations

### 12.1 Track Event Format

The Track Event is comprised of three (3) on-track days around a closed-course track.

### 12.2 Determination of Single-Occupant Vehicle Winner

Overall placing for the FSGP Event will be determined based on the team with the highest total number of Official FSGP Laps calculated by summation of the laps driven during Track Event hours minus penalty Deductions. If there is a tie for Official FSGP Laps, the team with the lowest individual lap time wins.

### 12.3 Determination of Multi-Occupant Vehicle Winner

Multi-Occupant vehicle teams will be ranked according to their S value (highest score is best).

$$S = (D / E) \times C \times T$$

Where D is the Total Person-Mile Distance, E is the Total External Energy usage of the solar car, C is the Completion Factor, and T is the Target Speed Derate.

Any team that fails to complete the Minimum Event Distance Driven will automatically be ranked below all teams that successfully complete it.

$$\text{Minimum Event Distance Driven} = (\text{Total Event Driving Hours}) \times (20 \text{ MPH})$$

#### 12.3.A Person-Mile Distance (D)

A team's Person-Mile Distance will be calculated for the Event. The Lap Person-Mile Distance is the lap distance in miles multiplied by the minimum number of seats occupied in the solar car during that lap. Person-Miles are only awarded for valid laps completed by the solar car. The summation of these Lap Person-Mile Distances will yield a Total Person-Mile Distance for the entry.

#### 12.3.B External Energy Usage (E)

Total External Energy usage of a Multi-Occupant vehicle will be calculated as:

$$(n+1) \times Q + M$$

Where n is the number of times the energy storage system is charged from unmetered external energy between the start and end time of the Event, Q is the energy capacity of the energy storage system in kWh, and M is the total metered external energy in kWh used to charge the energy storage system during the Event.

**12.3.B.1** The energy capacity (Q) of the energy storage system will be calculated in kWh by the Event Organizers based on the manufacturer's battery cell datasheet and the number of cells in the system.

**12.3.B.2** Multiple unmetered charging sessions will be counted as a single unmetered charge as long as the solar car is not driven in the Event between the charging sessions.

**12.3.B.3** Charges from metered external energy shall be conducted in accordance with Reg. 8.10. The energy from all metered external energy charges will be added up to calculate the total metered external energy in kWh. If for any reason an external charge is not properly metered and recorded, it will count as charging from unmetered external energy.

#### 12.3.C Completion Factor (C)

The Completion Factor is calculated by:

Official Distance / Highest Driving Distance of Any MOV Entry

#### 12.3.D Target Speed Derate (T)

**12.3.D.1** V is the Target Average Speed which is equal to 30 miles per hour.

**12.3.D.2** Va is the team's Overall Average Speed which will be calculated as the average speed of all valid laps completed by the solar car over the course of the Event, in miles per hour.

**12.3.D.3** If  $V_a \geq V$  then the target speed has been met and the Target Speed Derate will be calculated as:  
 $T = 1$

**12.3.D.4** If  $V_a < V$  then the target speed has not been met and the Target Speed Derate will be calculated as:  
 $T = 0.6^{((V - V_a) / 0.4)}$

## **12.4 Solar Car Configuration**

Solar Cars must drive in the same configuration as approved during Scrutineering.

## **12.5 Radios / Communication**

The team must be in two-way radio communication with the solar car driver at all times. Communications should be maintained between the solar car, the pit area, and the timing area at all times.

Driver communication requirements are found in Reg. 11.6. Cell phones MAY be allowed as the primary communications device during the Track Event, depending on line-of-sight obstructions to 2-way radio communication at the track selected for the event.

## **12.6 Authority**

Headquarters reserves the right to cancel the track activity at any time for the Event as a whole or for any particular team.

## **12.7 Safety**

### **12.7.A Safety Equipment**

**12.7.A.1** Teams are required to have the safety equipment readily available as outlined in Reg. 3.1.B

**12.7.A.2** Their battery spill kit must be available in the pit area at all times.

**12.7.A.3** Teams shall have first aid supplies in their pit area at all times.

**12.7.A.4** Any team member in the hot pit or going on the track to assist with a broken-down vehicle must be wearing a safety vest and closed toed shoes.

### **12.7.B Support Vehicles**

No support vehicles will be allowed on the track without prior consent by Track Officials.

### **12.7.C Safety Vehicles**

Designated safety vehicles will be driven by an Official(s). If a track safety vehicle is needed, it will attempt to stay in the slow lane of the track. The same rules that apply to passing solar cars also apply to passing the safety vehicle. Teams may pass a static safety vehicle during a yellow flag condition as well as any solar car not moving given the conditions are safe to pass.

## **12.8 Briefings**

A Briefing will be held at the start of each Event day. A special meeting may be called in cases of emergency. Attendance at meetings by a team representative and driver(s) is required. Briefing notes and other daily updates will be available at Headquarters and/or communicated through each team's Generic Team Email. All official statements, rule interpretations, and special instructions will be contained in these postings.

## **12.9 Timing**

### **12.9.A Responsibility**

Headquarters will only recognize timing and distance information from the Event Timing Officials.

### **12.9.B Timers**

Each team must provide a team member to serve as a timer. This team member must be in radio contact with both the solar car driver and the pit crew. The timer will be paired with a timer from another team, and the two will work together to ensure that every lap is properly recorded. Timing Officials will review all timing data for consistency and accuracy. The timer must report 15 minutes prior to the start of the Event. Any laps conducted by the solar car without a timer in place or without being recorded by the timer and verified by a partner team will not be counted. MOV teams may choose to invalidate a slower than desired lap if they notify Timing Officials prior to the completion of the lap.

### **12.9.C Official Time**

A master clock providing the "Official Time" will be located near the starting line and timing area. A solar car must cross over the start line to begin and end an Official FSGP Lap. All timers must record lap start/finish times based on the official time displayed.

## 12.9.D Transponders

If available, the track's timing system will be utilized for lap time verification and as a secondary reference for lap counts. Teams should be prepared to affix an electronic transponder to the solar car such that it reliably triggers the track's receiver (typically in a wheel fairing with a clear line of sight to the ground). Additional instruction will be provided at the Event.

## 12.9.E Track Hours

The track will be open for driving from 10:00 am – 6:00 pm local time (Day 1) and 9:00 am – 5:00 pm local time for Days 2 and 3.

## 12.10 Starts

### 12.10.A Group Start

Teams are released from the Start Line in a group start. The movement of all vehicles in the Start Line area will be under the control of the Start Line Officials.

### 12.10.B Starting Order

For the first day of the Track Event, the starting order will be determined based on performance at Scrutineering. On subsequent days the start order will be determined based on the total number of Official FSGP Laps completed thus far.

### 12.10.C Start Line

Solar cars will be released simultaneously from the starting line at the beginning of each day. Teams must report to their starting position 15 minutes prior to the beginning of the start time. Control of solar cars in the start line area is under the direction of the Start Line Officials. Teams not ready or who are returning to the track from the cold pit area must wait for a Track Official to clear them for the starting line and be sequenced into traffic.

### 12.10.D Delayed Start

The start of the Track Event may be delayed if inclement weather or other hazardous conditions appear likely to pose a threat to the solar cars or their drivers. If the start of the Track Event is delayed, then the assigned start time for that day will be adjusted accordingly. The end of the day will not be adjusted.

## 12.11 End of Day

### 12.11.A End of Day

At 6:00:00 pm (Day 1) or 5:00:00 pm (Days 2 and 3) the Checkered Flag will be flown at the Start/Finish line. A team currently on a lap started in advance of the End of Day time will be given the opportunity to complete that lap, provided that the lap time for that final lap is no more than 20% greater than the time for the preceding lap.

## 12.12 Charging/Impound

All battery enclosures shall be secured overnight in impound configuration by the Inspectors. Headquarters should be appraised of special issues for impound.

### 12.12.A Charging

All solar cars may begin the Track Event with a fully charged battery pack. Once the Track Event begins, charging may only occur using the solar car's array in designated charging areas.

**12.12.A.1** Charging from other sources will result in a penalty associated with Official FSGP Laps completed to that point, reference Reg. 13.4.H.

**12.12.A.2** All charging of solar car batteries shall be monitored by a team member. Unattended charging of the solar car batteries is strictly prohibited.

**12.12.A.3** A solar charging area will be provided for the teams. Internal combustion generators will not be permitted within this designated charging area which is restricted to solar charging only.

**12.12.A.4** Multi-Occupant vehicles are allowed to re-charge their battery packs as per the procedure and scoring of Regs. 12.3.B.3 and 8.10.

## 12.12.B Impounding

All registered and sealed batteries must be secured in the impound configuration (Reg. 8.10) that was inspected during Scrutineering and will be secured by the Inspectors. Batteries must be impounded by 8:00 pm each evening and will be released from impound at 7:00 am the following morning.

**12.12.B.1** If an SOV team doesn't impound overnight, they forfeit all Official FSGP Laps completed to that point. Reference Reg. 13.4.K for failure to impound on time.

**12.12.B.2** Multi-Occupant vehicles can maintain access to their vehicle for metered external energy charging. Battery impound is not required for MOV unmetered external energy charging. Any time a team elects to charge from unmetered external energy they must first officially declare this intention to the Event Organizers.

## 12.13 Driving Procedures

All solar cars will proceed around the course in the prescribed direction at all times. Passing and lane information will be presented at the pre-Track Event team meeting.

### 12.13.A Speed Limit

No solar car shall exceed the maximum speed of 104.2 km/h (65 mph), unless further restricted by the Officials per Reg. 10.9.B anywhere on the track. All teams entering the pit area must slow down. A walking pace must be observed at all times in the cold pit area. While in the cold pit area a team member shall walk directly in front of the solar car to ensure that the path is clear and to warn others in the area.

### 12.13.B Following Too Closely

No solar car shall follow a proceeding car too closely.

### 12.13.C Pushing

Except for the following situations, solar cars may not be pushed or pulled from the time they are moved into their starting position for the daily start until they reach the finish line except in the cold pit areas. In no case shall regenerative braking be engaged while pushing or pulling the solar car.

**12.13.C.1 Garage Area:** Solar cars may be pushed within the confined areas of the Cold Pit or Garage Area.

**12.13.C.2 Emergency:** In an emergency or breakdown situation, the solar car must be removed from the track as quickly as is prudent. In this circumstance, the car may be pushed or lifted off the track. Upon resuming driving, the solar car may then be pushed or lifted back onto the track to the same location where it left the track.

**12.13.C.3 Penalty:** Should the team push the car on the track, a penalty will be applied as per Reg. 13.4.D

## 12.14 Breakdowns

Any solar car that stops on the track because of mechanical problems, lack of power, or an accident must be moved off the track as soon as possible and prior to any repairs being performed.

All teams must carry a tow strap in their solar car at all times. This tow strap will be used to facilitate a tow to the pit area by the safety vehicle, if required. The tow strap must be sized appropriately to tow the solar car with a driver inside, must be long enough to extend at least 3 m (10 ft) in front of the leading edge of the vehicle when installed, and must have closed hooks on both ends. No ratchet straps are allowed. Laps where a solar car is towed in are invalidated and do not count as laps driven.

Team members may not run across the track to their solar car unless permission is granted by a Track Official. All team members attending to a broken-down car on the track must be wearing a safety vest.

At the discretion of the Inspectors, any car having a breakdown may be required to be re-inspected for safety and rules compliance.



## 12.15 Track Operation

### 12.15.A Flags

Flags will be used to provide trackside instruction to solar car drivers.

**12.15.A.1 Master Flag Position:** The Master Flag Position will be near the starting line and display flag(s) to represent the overall condition of the track. Corner workers will be located at various Flag Positions around the course to display “local” flag conditions.

**12.15.A.2 Green Flag:** Track clear; proceed at your chosen speed. This flag will be displayed at the starting line only.

**12.15.A.3 Blue Flag:** Caution ahead, proceed at your chosen speed, passing is allowed. This flag will be displayed at corners to alert drivers to unusual conditions ahead that do not immediately interfere with the track (such as a car stopped off of the track).

**12.15.A.4 Yellow Flag:** Caution, obstruction on or near track. A yellow flag means that cars are to slow down and no passing is allowed unless waved around by a Track Official. The no passing rule will continue to apply until the solar car reaches a Flag Position where no flag is displayed. Whenever a yellow flag is somewhere on the track, the Master Flag Position will display both the green and yellow flags.

**12.15.A.5 Black Flag:** Return to the pit area immediately. A black flag is given to an individual car at which point the driver must return to the pit area. The black flag will appear at the last corner before pit entry.

**12.15.A.6 Red Flag:** Total stoppage due to major accident or some other reason. All cars must pull to the side and stop where they are on the track without passing. Proceed only when instructed to do so by Track Officials.

**12.15.A.7 White Flag:** This flag will be displayed at the starting line only at five (5) minutes before the end of day time and signifies that there is less than five (5) minutes remaining in the race day.

**12.15.A.8 Checkered Flag:** This flag will be displayed at the starting line only at the end of day time and signifies that the race day is over, save and except for the stipulation in Reg. 12.11.A.

## 13. Penalties

Any team failing to comply with these Regulations during Scrutineering or the Track Event will be penalized. Penalties range from official warnings to disqualification from the Event. It is the responsibility of the Chief Inspector and/or Track Steward, with input from the other Inspectors and track personnel, to determine whether an infraction occurred, the severity of the incident, and the appropriate penalty. All penalties will be submitted by the Chief Inspector and/or Track Steward to Headquarters for subsequent posting. Disqualification of a team from the Event requires concurrence of the Event Director. For the Track Event penalty Deductions will generally be applied to total number of Official FSGP Laps.

### 13.1 Penalty Distance/Laps

#### 13.1.A Penalty Distance

All penalty distances listed are suggested minimums. Driving conduct penalties may double with each subsequent infraction. Scrutineering and other technical penalties will normally be the same for each infraction. If the Inspectors believe the teams are deliberately violating traffic or driving regulations for strategic advantage, they may impose more severe penalties up to and including potential disqualification.

#### 13.1.B Penalty Laps (Track Event)

For each Track Event infraction, Penalty Distance will be converted to Penalty Laps based upon the length of the track (rounded up to the next lap). Penalty Laps are deducted from laps driven to determine Official FSGP Laps.

#### 13.1.C Scrutineering Issues

Scrutineering issues may result in a pre-loss of laps (Track Event) as determined by the Inspectors prior to the beginning of each of the Track Event days. Examples of Scrutineering issues include but are not limited to: car size exceeds limits. Typically, these issues are the result of receiving a blue status in any inspection area. Issues within the dynamics area may also result in a reduced speed limit for the solar car on the track.

#### 13.1.D Posting of Penalties

Penalties will be publicly posted each evening. On the last day of the Track Event, penalties will be posted no later than 2 hours after the finish of the Track Event.

## 13.2 Protests

Each team shall designate a single individual who acts on behalf of their team to file protests. Official protest filings are to be submitted to [protest@americansolarchallenge.org](mailto:protest@americansolarchallenge.org). Protests may be filed for any reason, including disputing a penalty levied against any team, correcting timing errors, or protesting the actions of another team. A "filing fee" Deduction of 5 miles will be assessed against the team's Official FSGP Laps for the day on which the protest is filed. The Jury will hear all protests. Jury meetings will be held in private. A representative of the team(s) involved may attend deliberations concerning disputes regarding their team to give evidence and respond to questions from the jury, but not the vote. A representative of the Event may attend deliberations to give evidence and respond to question from the jury, but not the vote.

#### 13.2.A Opportunity to Be Heard

Protests will normally be heard by the Jury at the earliest possible Jury sitting. It may be necessary in some instances for the Jury to postpone the hearing on a protest.

#### 13.2.B Time Limit

Except for the last day, all protests must be filed by 8:00 am the morning after the penalty is posted. On the last day of the Track Event, protests for any purpose must be filed within 30 minutes after the finish of the Track Event or after a team is notified of their penalties, whichever is later.

#### 13.2.C Protest Judgements

The decision of the Jury is final and no further appeals are allowed. The Jury will notify Headquarters of their decision, and the Chief Inspector and/or Track Steward or delegate will then inform the affected team(s). The Jury may refund some or all of the filing fee, which will be credited to the day the filing fee was assessed.

## 13.3 Conduct

Penalties, including disqualification from the Event, may be imposed for improper conduct or the use of alcohol or illegal substances. Improper conduct may include, but is not limited to, improper language, unsportsmanlike conduct, unsafe behavior, or cheating. Teams are responsible for the conduct of all persons associated with the team, whether or not they are officially registered.

## 13.4 Penalties

The following outlines the distance values.

For Multi-Occupant vehicles, penalties will be levied against the Completion Factor portion of the score, as described in 12.3.C.

### 13.4.A Speeding

Any solar car found to be speeding will be penalized. Speeding penalties may be assessed based on the following factors: (1) velocity over posted speed limits, (2) length of time of speeding infraction, (3) location of speeding infraction (i.e. no passing zone). Speeding infractions including a rate of speed of 112.6 km/h (70 mph) or greater will result in a 10 mile penalty in addition to the calculated assessment.

### 13.4.B Track Operation Violation

Any solar car committing a track operation violation may be penalized, up to disqualification. Any solar car driver who commits three (3) track violations (including speeding) over the course of the Track Event may be individually disqualified from the Event.

### 13.4.C Failure to Allow Other Solar car to Pass

Any team solar car that fails to properly facilitate passing by other teams may be penalized a minimum of 5 miles.

### 13.4.D Pushing

A loss of the current lap will result each time a team pushes or pulls their solar car in order to advance along the track. (Except in the exclusions as per Reg. 12.13.C)

### 13.4.E Improper Ballast

A 25 mile penalty may be assessed each time a team operates their solar car with ballast that does not match the solar car occupant.

### 13.4.F Unauthorized Drivers / Occupants

Any solar car that is driven on the track with an unauthorized driver or contains an unauthorized occupant will forfeit double the number of laps driven with said driver / occupant

### 13.4.G Driving Outside of the Event Day

Teams will be penalized two (2) miles for every (1) minute they continue to drive past the time they were supposed to stop.

Teams will be penalized two (2) miles for every (1) minute they start driving earlier than the time they were supposed to start.

### 13.4.H Non-Solar Charging of Batteries

After the start of the Track Event until the official finish, teams will be disqualified from the Event for charging their solar car's storage batteries from any source other than those allowed by Reg. 8, without specific written instruction from the Officials. Such charging of a solar car storage battery will constitute replacement and is subject to Reg. 13.4.J.

Multi-Occupant vehicles are exempt from this penalty.

### 13.4.I Disturbing Official Battery Seals

Solar car batteries will be marked with an official seal. Disturbing these seals in a manner that prevents proper identification by Inspectors may be penalized as though all of the battery modules affected had been replaced as in Reg. 13.4.J.

### 13.4.J Replacement of Batteries

Decisions to exchange (or externally recharge – see Reg. 13.4.H) all or part of a battery must be communicated formally to an Inspector. The penalty will be computed as follows:

$$\text{Distance penalty (miles)} = 480 \times (n+S) / N$$

where:

n = number of replacement modules

S = sum of all modules previously replaced

N = total number of modules in solar car battery pack

#### **13.4.K Failure to Impound**

A 2 mile penalty may be assessed for every minute that the team fails to impound their batteries.

#### **13.4.L Exceeding Size Specifications**

Oversized solar collectors will be penalized 15 miles per day per excess 1000 cm<sup>2</sup> beyond the allowed size specification. Oversized solar cars will be penalized 7 miles per day per excess 1000 cm<sup>2</sup>. If both the array and car are oversized, both penalties will be applied. Each penalty will be pro-rated if the oversize area for body or array is less than 1000 cm<sup>2</sup> with a minimum of 2 miles per day for oversized solar collectors, and a minimum of 1 mile per day for oversized solar cars.

#### **13.4.M Securing of Fasteners**

Failure to comply with Reg. 10.4.B Securing of Fasteners will result in a penalty of 1 mile per bolt per day per instance where proper securing is not applied. The Head Mechanical Inspector shall determine which non-compliant fasteners must be brought into compliance with Reg. 10.4.

#### **13.4.N Parking Brake Penalty**

A 10 mile per day penalty will be applied for a non-functioning parking brake based on Reg. 10.6.

#### **13.4.O Roll Cage Clearance Penalty**

A 2 mile per day penalty will be applied for each centimeter of clearance lacking between the roll cage padding and a driver's helmet based on Reg. 10.3.A.15. It will be at the discretion of the Inspectors whether less clearance will be allowed with application of the penalty.

#### **13.4.P Ignoring BPS Fault Indicator**

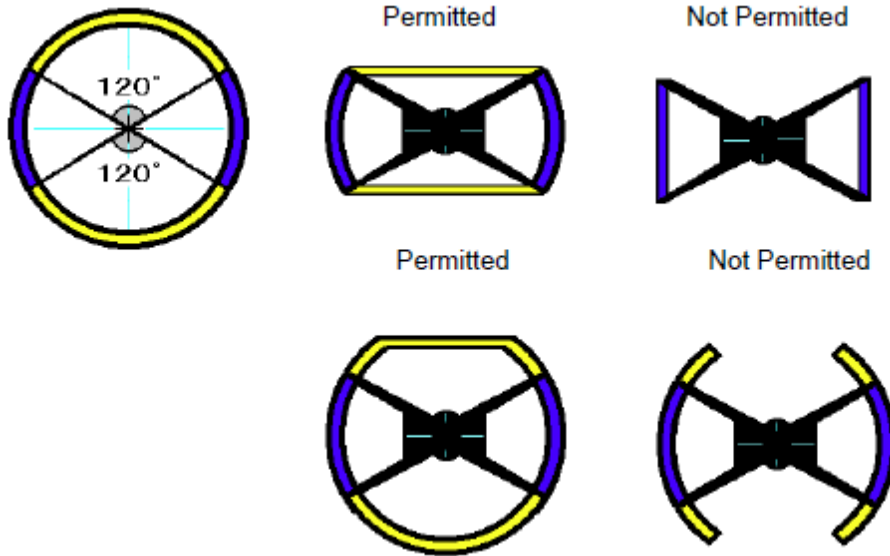
A 2 mile penalty will be applied for each occurrence that the team ignores the BPS Fault Indicator and continues to drive on the track.

# Appendix A. Steering Wheel Specifications

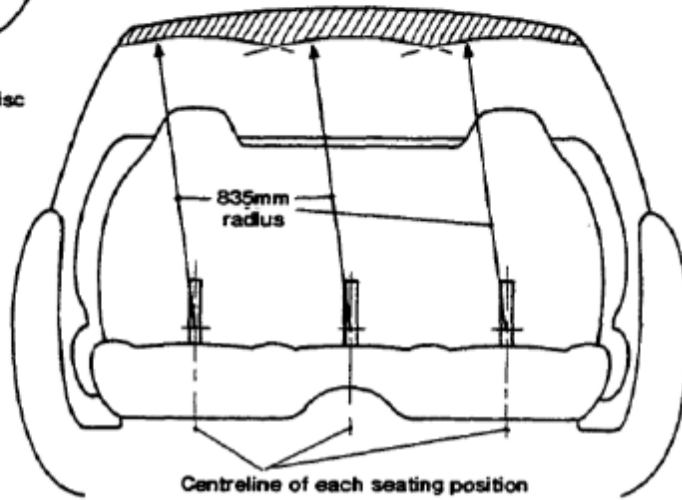
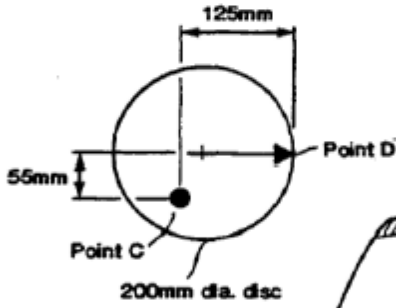
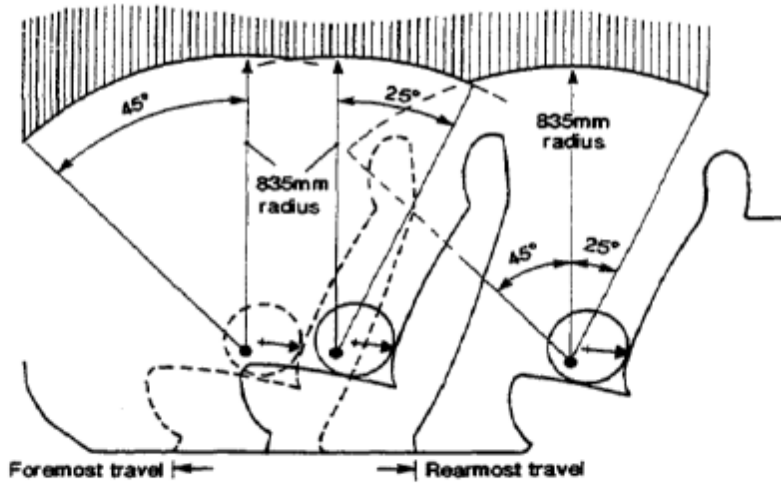
© 2006/08 with acknowledgement to Japanese Automobile Federation

To reduce the possibilities of driver injury in the event of collision and to minimize impediments to emergency egress, the steering system must be controlled by a steering wheel which has a continuous perimeter.

A circular shape is preferred, however the upper part above 2/3 and/or the lower part below 2/3 of the circumference of the steering wheel may be flat as depicted in the diagram below).



# Appendix B. Occupant Space Diagram



## Appendix C. Reference Standard for Lighting

Reference Reg. 9.4.

The reference standard lights are:

TruFLEX

20 LED (Length 3.35 in)

Item TF20 from Custom Dynamics

Red lights are Red LED with Red lens

Amber lights are Amber LED with Amber lens

([www.CustomDynamics.com](http://www.CustomDynamics.com) 1-800-382-1388)

White lights are TF6WC for the BPS Fault Indicator Light and Daytime Running Lights/Headlights

Note: The TF6WC has been discontinued. Custom Dynamics has recommended the MS6 part as a replacement. The reference standard will continue to use the TF6WC part for 2024.

The reference standard lights will be used in the following manner:

Lights shall be powered by a 12 volt power source

Light shall be centered on a flat surface with a matte white finish of 11" x 8.5".

Separate light boards shall be used for each color type as the standard reference.

Reference standard light boards shall be set aside of car to compare during inspections.

## Appendix D. PVDR - Instructions

It is the intent of the Event to maintain the safest entries possible while encouraging a wide variety of designs and materials for solar-powered vehicles. The purpose of the structural report is to require each team to document, by calculation or testing, the structural integrity of their vehicle and the protection provided to their drivers. Note that each team is responsible for the safety of its members, and any minimum criteria specified by the Organizers should not be construed as design specifications for the construction of a “safe” solar vehicle.

The Preliminary Vehicle Design – Mechanical and Electrical report as per Reg. 5.1 should outline the basic mechanical, structural, electrical and battery design of the vehicle. It should be written to be as concise as possible, limited to a total of 20 pages. The report shall be submitted in PDF format, and the text have at least 10-point font.

Report format shall be a single PDF Package containing: (1) technical document on your mechanical system, and (2) an overview of the electrical approach to the solar vehicle. PDF Package file names shall contain sponsoring organizations name\_FSGP2025PVDR. Example: a report from the University of ACME may appear as “UnivOfACME\_FSGP2025PVDR.pdf” with the first letter of each new word capitalized and common abbreviations accepted.

The report should describe:

### D.1 Mechanical:

Teams shall submit the mechanical reports following the form (Appendix E) provided using the form as a cover page and table of contents to the report.

This form provides a format for the preliminary vehicle design report that must be completed in its entirety and included as the first page of the report.

### Mechanical Loading Conditions

Teams shall consider road and traffic conditions when determining loading criteria and potential failure modes. For suspension and steering systems, analysis shall include a minimum of **1G turn, a 2G bump, and 1G braking** case loads with a worst-case condition of the loads combined. These loads shall to be applied at the **wheel patch** where the tire makes contact with the ground. Loads shall be provided in dimensional units, along with any relevant assumptions used in the analysis.

### D.2 Electrical & Battery:

- (1) An overview of the electrical approach to the solar vehicle
- (2) Electrical Team leader contact information (phone & email)
- (3) A preliminary electrical diagram showing greater than 24-volt service plans.
- (4) Preliminary battery approval document including the battery team leader contact information (phone & email)
- (5) Battery types and suppliers/manufacturers’ being considered if one is not already chosen
- (6) Battery testing plans with critical dates.
- (7) Battery Cell Manufacturing URL



# Appendix E. Mechanical PVDR Form



## Mechanical PVDR Form

School/Team: \_\_\_\_\_ Entry # \_\_\_\_\_

### Mechanical PVDR/Table of Contents

- 1. History of team and vehicle (one paragraph) page \_\_\_\_\_
- 2. **Type of vehicle:** Single-Occupant (\_\_\_), Multi-Occupant (\_\_\_) check one
- 3. Complete vehicle weight in driving configuration: with batteries, with ballasted driver/occupants, etc. (\_\_\_\_); Units (\_\_\_) kg (\_\_\_) lbs,
- 4. Vehicle description shall be presented by profile and top view drawings showing the placement of major components such as driver, battery, ballast box, seat belts mounting points, etc, along with overall dimensions including wheel base and tread page \_\_\_\_\_
- 5. **Frame/chassis and roll cage type:** tubular frame (\_\_\_), composite (\_\_\_), check one. Drawing shall show the driver positioned in the frame/chassis, compliance with Reg 10.3.A,10.3.B,10.3.C, and description of method of construction page \_\_\_\_\_
- 6. **Roll cage:** Profile and frontal drawings shall show compliance with Regs 10.3.A page \_\_\_\_\_
- 7. **Seat Belts:** 5 point (\_\_\_), 6 point (\_\_\_), check one Drawing shall indicate location of mounting points and compliance with Reg. 10.3.E page \_\_\_\_\_
- 8. **Braking system:** Front wheel only (\_\_\_), Front-rear (\_\_\_), check one. Schematic and description of primary braking system shall show compliance with Regs.10.5 and 10.6 (include the braking performance calculations) page \_\_\_\_\_
- 9. **Steering system type:** rack and pinion (\_\_\_), other (\_\_\_), check one. Description shall include component selection and specs page \_\_\_\_\_
- 10. **Front suspension:** type: a-arm (\_\_\_), other (\_\_\_), check one Description shall include drawing/photos, component selection and engineering analysis demonstrating proper selection and sizing of rod ends with shear loads page \_\_\_\_\_
- 11. **Rear Suspension:** type: a-arm (\_\_\_), swing arm (\_\_\_), other, check one. Description shall include drawing/photos with component selection and specs, and engineering analysis demonstrating proper selection and sizing of rod ends with shear loads page \_\_\_\_\_
- 12. Description of method of analysis to be used to prove structural integrity For loading conditions as per Appendix D, Section D.1 page \_\_\_\_\_
- 13. **Windshield:** material (\_\_\_\_\_) Include data sheet showing compliance with 9.5.C.2 page \_\_\_\_\_

-----

Mechanical contact: Name: \_\_\_\_\_  
 Email address: \_\_\_\_\_  
 Phone: \_\_\_\_\_

Project Manager: Name: \_\_\_\_\_  
 Email address: \_\_\_\_\_

## Appendix F. Mechanical Report Instructions

It is the intent of the Event to maintain the safest entries possible while encouraging a wide variety of designs and materials for solar-powered vehicles. The purpose of the structural report is to require each team to document, by calculation or testing, the structural integrity of their vehicle and the protection provided to their drivers. Note that each team is responsible for the safety of its members, and any minimum criteria specified by the Event should not be construed as design specifications for the construction of a "safe" solar vehicle.

The structural report shall be presented in the format described in this document. Reports that do not meet this format will not be read and could jeopardize a team's chances for competing in the Event. The report should be written to be as concise as possible and should only present information relevant to the requirements of the report. The report is limited to a total of 30 pages, including appendices and submitted in PDF format.

### F.1 Report Presentation

Teams shall submit the mechanical reports following the form (Appendix G) provided using the form as a cover page and table of contents to the report. This form provides a format for the vehicle design report that must be completed in its entirety and included as the first page of the report.

### F.2 Loading Conditions

Teams shall consider road and traffic conditions when determining loading criteria and potential failure modes. For suspension and steering systems, analysis shall include a minimum of **1G turn, a 2G bump, and 1G braking** case loads with a worst-case condition of the loads combined. These loads shall to be applied at the **wheel patch** where the tire makes contact with the ground. Loads shall be provided in dimensional units, along with any relevant assumptions used in the analysis.

### F.3 Vehicle Impact Analysis

The vehicle impact analysis section must include the following topics:

**F.3.1 Specifications:** The report must describe the vehicle frame and construction techniques (aluminum space frame, composite monocoque, etc.), including the materials utilized, their important dimensions (e.g., tubing diameters and thicknesses, number and types of plies in composite constructions), and their properties (in the "as welded" or "as fabricated" condition). The report must also list the specific impact criteria that are assumed for each case, as well as sample calculations and computer output as applicable. Other relevant assumptions used in the analysis should be listed.

**F.3.2 Drawings:** The report must include structural drawings of the vehicle from five viewpoints: top, front, side, rear, and isometric. These drawings must illustrate the following:

- Driver location and orientation
- All members considered "structural"
- Locations of ballast and batteries
- Locations of chassis hard points (points of attachment).
- Calculated center of mass

The report must contain structural drawings of the driver's compartment from three viewpoints: top, front, and side. These drawings must illustrate the following:

- Driver location
- Roll cage design and location
- Location of structural members
- Driver's harness attachment points

The report must contain an isometric drawing of the body and solar collector, a. All drawings must be identified by number and must include a description.

**F.3.3 Analysis:** Analyses may be in the form of computer modeling (such as a finite-element analysis) or empirical testing of the actual vehicle or its components. For finite-element analysis of the roll cage, 3D elements shall be used for analysis of all joints. Either a full 3D element model of the roll cage shall be used, or a shell or beam model of the roll cage shall be used to set the boundary conditions for detailed 3D models of each joint that extend at least 2x the tube diameter from the toe of the weld. Shell or beam elements are acceptable for analysis of the remainder of the occupant cell. Shell elements shall be acceptable for finite-element analysis of the roll cage if the factor of safety is 1.4 or greater. In any case where a minimum factor of safety of less than 1.1 is reported via finite-element analysis, additional data shall be required to validate the finite element model.

**F.3.3.1 Occupant Cell Impact:** Front, rear, and side impact with another vehicle assumes a bumper height of 100 mm, a width of 600mm, and elevation off the ground of 350 mm as shown in Figure 5. The occupant cell shall not deform more than 25 mm and shall not exceed ultimate strength, but can yield (10.3.A.9). The required load cases are:

1. Front
2. Rear
3. 3 side impact locations. One of these locations shall be the worst case bending moment on the side of the occupant cell.

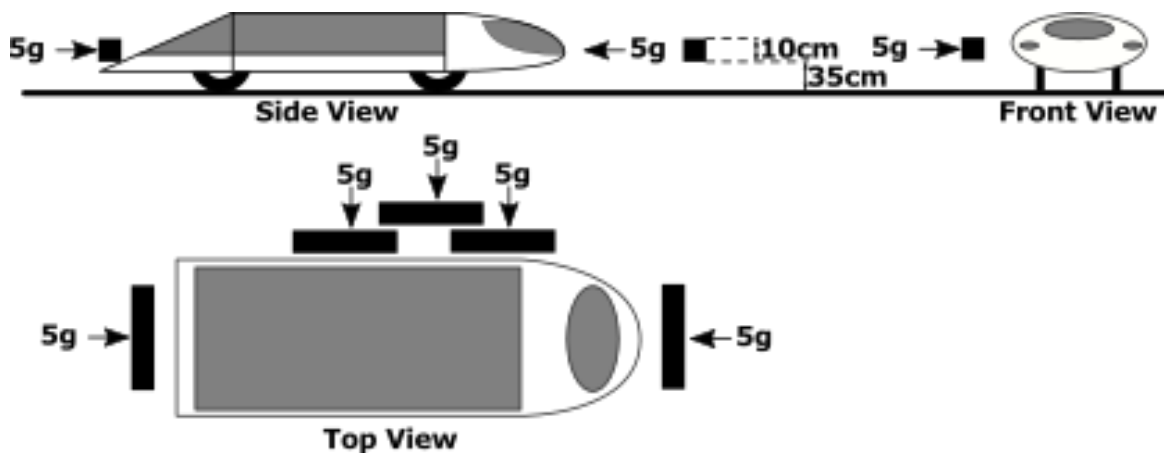


Figure 5 Occupant Cell Impact Loads

**F.3.3.2 Roll Cage Impact:** Roll cage impact scenarios shall have a loading patch no more than 150mm diameter. The roll cage can not exceed yield strength (10.3.A.9). The required load cases are:

1. Combined Loading (5g down, 4g backward, 1.5g lateral)
2. Sideways angled loading (5g at 30 degrees downward from horizontal)
3. Sideways angled loading (5g at 60 degrees downward from horizontal)
4. Sideways horizontal loading (5g at the top of the hoop)
5. Rearward horizontal loading (5g at the top of the hoop)

Each load case should be evaluated when applied to the front and rear roll hoop (10 load cases total). An example of the combined roll cage loading case for the front hoop is included in Figure 6.

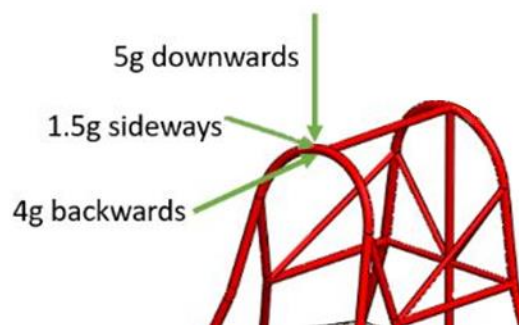


Figure 6 Combined Roll Cage Load Case (Front Hoop)

Emphasis should be placed on how protection is provided for the driver under these conditions. All impact scenarios must take into account movement of body panels and the vehicle's solar collector to ensure that these members do not penetrate the space occupied by the driver during the impact.

**F.3.4 Conclusions:** The report should contain a summary of the findings for each impact case and a brief discussion of the results. Raw data should be attached as an appendix to the report.

#### **F.4 Appendix**

The appendix should only include relevant information that is referenced from the main body of the report. Appendix items should be organized into two appendices. Examples of what could possibly be included in the appendices are: detailed calculations and results, empirical testing data, details on construction techniques, and component specifications that are particularly relevant to the analysis.

- **Appendix A** - Mechanical Systems Analysis Supporting Documentation
- **Appendix B** - Vehicle Impact Analysis Supporting Documentation

## Appendix G. Mechanical VDR Form



# Mechanical VDR Form

School/Team: \_\_\_\_\_ Entry # \_\_\_\_\_

## Mechanical VDR/Table of Contents

1. History of team and vehicle (one paragraph) page \_\_\_\_\_
2. **Type of vehicle:** Single-Occupant (\_\_\_), Multi-Occupant (\_\_\_) check one
3. Complete vehicle weight in driving configuration: with batteries, with ballasted driver/occupants, etc. (\_\_\_\_); Units (\_\_\_) kg (\_\_\_) lbs,
4. Vehicle weight distribution (estimate), front (\_\_\_\_), rear (\_\_\_\_), lbs/kg.
5. Vehicle static stability analysis, compliance with 10.2.C page \_\_\_\_\_
6. Vehicle description shall be presented by profile and top view drawings showing the placement of major components such as driver, battery, ballast box, seat belts mounting points, etc, along with overall dimensions including wheel base and tread page \_\_\_\_\_
7. **Frame/chassis and roll cage type:** tubular frame (\_\_\_), composite (\_\_\_), check one. Drawing shall show the (1) occupants positioned in the frame/chassis, (2) material specs of all metal components, and (3) compliance with Reg. 10.3.A. page \_\_\_\_\_
8. **Roll cage:** Profile and frontal drawings shall include material specs and show compliance with Regs. 10.3.A, 10.3.B, 10.3.C page \_\_\_\_\_
9. **Seat Belts:** 5 point (\_\_\_), 6 point (\_\_\_), check one Drawing shall indicate location of mounting points and compliance with Reg. 10.3.E page \_\_\_\_\_
10. **Braking system:** Front wheel only (\_\_\_), Front-rear (\_\_\_), check one. Schematic and description of primary braking system shall include parking brake and component specs demonstrating compliance with Regs. 10.5 and 10.6 (include the braking performance calculations) page \_\_\_\_\_
11. **Steering system type:** rack and pinion (\_\_\_), other (\_\_\_), check one. Description shall include component selection and specs page \_\_\_\_\_
12. **Steering stops:** Description/drawing/photos shall show compliance with Reg. 10.7.B. page \_\_\_\_\_
13. **Front suspension:** type: a-arm (\_\_\_), other (\_\_\_), check one Description shall include drawing/photos, component specs, and engineering analysis demonstrating proper selection and sizing of rod ends with shear loads under applied loads as specified in Appendix F, section F.2 page \_\_\_\_\_
14. **Rear Suspension:** type: a-arm (\_\_\_), swing arm (\_\_\_), other, check one. Description shall include drawing/photos, component specs, and engineering analysis demonstrating proper selection and sizing of rod ends with shear loads under applied loads as specified in Appendix F, section F.2 page \_\_\_\_\_
15. **Tires and rims:** Description shall include brand, load, speed, and pressure rating to comply with Reg. 10.2 page \_\_\_\_\_
16. **Hub design:** Drawings showing wheel-hub assembly page \_\_\_\_\_
17. **Battery box:** Description/drawing to show how battery box is constructed and secured in the chassis as per Reg. 8.4.B page \_\_\_\_\_
18. Description/drawing to show independent methods of array attachment as per 10.1.C page \_\_\_\_\_
19. **Fasteners:** Description of compliance with Reg. 10.4 page \_\_\_\_\_
20. **Vehicle Impact Analysis:** Method: Classical (\_\_\_), FEA (\_\_\_), Testing (\_\_\_) Analysis shall be performed as per Appendix F Section F.3 and the results shall be presented in terms of factor of safety in tabulated form page \_\_\_\_\_

-----

Mechanical contact: Name: \_\_\_\_\_  
Email address: \_\_\_\_\_  
Phone: \_\_\_\_\_

Project Manager: Name: \_\_\_\_\_  
Email address: \_\_\_\_\_

# Appendix H. Battery Approval Form



## Battery Approval Form

The manufacturer's specification sheet, the battery's MSDS sheet with accident protocol, and a description of the protection circuitry (protection circuitry schematic, high level description, list of items protected) must also be submitted to Headquarters prior to approval. Battery approval is subject to verification at Scrutineering. If the manufacturer changes the battery's specifications, the new specifications must be submitted for re-approval. Teams should bring unmodified cells for weight verification.

**Note:** For this form, the term "battery" refers to the smallest single unit produced by the manufacturer (usually containing one cell). Teams or suppliers may group batteries together to form "modules". The term "pack" refers to the full vehicle battery system made up of multiple batteries.

### TEAM CONTACT INFORMATION

School Name: _____	Date: _____
Team Number: _____	Team Battery Contact Email: _____
Team Email: _____	Team Battery Contact Phone Number: _____

### BATTERY MANUFACTURER'S TECHNICAL SPECIFICATIONS

Manufacturer URL: _____	Type / Chemistry: _____
Battery Name: _____	Model Number: _____
Capacity (Ah): _____	Charge Rate: _____
Mass (kg): _____	Voltage (Min/Max/Nominal): _____
Cost (US\$): _____	Max Discharge Current: _____

### VEHICLE BATTERY PACK SPECIFICATIONS

Number of Batteries in Vehicle Pack: _____	Mass (kg): _____
Capacity (kWh): _____	Voltage (Min/Max/Nominal): _____
Pack Configuration: _____	

### BATTERY SUPPLIER INFORMATION

Information for the company that is supplying the batteries to the team. This may be the original manufacturer or a reseller. If the supplier uses a different model name or number than the manufacturer, please provide that information.

Supplier: _____	Contact: _____
Email: _____	Phone: _____
Supplier Battery Name: _____	Supplier Model Number: _____

## Appendix I. Solar Cell Report

Your report will be based on the type of solar collector you intend to use in the Event based on Reg. 8.1. The following are instructions on preparing your team's report.

Your report should contain the following:

- (1) Team Name
- (2) Team Number
- (3) Complete list of cells used on your solar collector. List should indicate (Reg. 5.2.F) for each unique type of cell used:
  - a. Cell manufacturer's name and contact info
  - b. Stock number, type, or description
  - c. Manufacturer's quote for cell area (square centimeters)
  - d. Manufacturer's quote for performance
  - e. Cell area (square centimeters)
  - f. Include a copy of the manufacturer's data sheets in the appendix of your report for each type of cell. *NOTE: you are only allowed a maximum of 6 types of cells. Any change in any of the cell characteristics would dictate a new cell type being used.*
- (4) A detailed breakdown of the size and dimensions of each type of cell listed in #4 after trimming or cutting as placed on the solar car. Show your calculations on how you determined cell area. Cell area should be in square centimeters (Reg. 5.2.F.5).
- (5) A detailed drawing showing the specific layout of your solar collector including how the array is broken into sub arrays and the layout for each solar cell indicating which type of cell is used where on the array (Reg. 5.2.F.6).
- (6) Calculations determining the total cell area for your whole solar collector. Show your calculations and use square centimeters (Reg. 5.2.F.6).
- (7) Show the calculations for determining the estimated power production of the whole solar collector in Watts at STC.
- (8) Indicate all other non-photovoltaic/ photovoltaic technology used as defined in Reg. 8 Report how these technologies will be used during driving and charging times. Indicate how these technologies will fit into the car volume allowed per Reg. 9.1.

### **All calculations should be reproducible by inspectors.**

The purpose of these reports is to pre-scrutineer your car's solar collector. Inspectors will compare your report to your car at Scrutineering. Be sure to remember to bring a sample raw solar cell (Reg. 8.1.F) of each type used to Scrutineering for validation purposes.



## Appendix J. Recommendations

These are not binding parts of the Regulations, as they are impractical to enforce fairly, but the Officials believe they are essential to creating a good, safe solar car. All teams should meet these recommendations on their own.

**Driver Training:** Driver Training is essential to ensuring your car can be driven safely. Solar vehicles have substantially different controls, field of vision, and feedback from regular vehicles. We recommend that every team trains all drivers in a gradual and controlled manner. This means that a driver will begin learning to handle the vehicle in a very controlled setting (such as a large closed parking lot or track) and progress to more challenging situations as he/she gains experience. Prior to any driving, the vehicle should always be given a safety check and the driver should have properly functioning safety equipment. As training progresses, the driver (and all team members in the caravan) should practice handling the following situations:

- (1) Blow-outs and run flats, especially of the single rear wheel on a three-wheel vehicle
- (2) Loss of power
- (3) Primary brake partial and complete failure
- (4) Passing protocols
- (5) Merging protocols
- (6) Road hazard avoidance
- (7) Moving to shoulder from operational speed
- (8) Caravan communication and protocols for possible emergencies
- (9) Emergency stop and egress

**Vehicle Stability and CG:** CG location has an important influence on vehicle stability. Your CG location should be a design requirement, not something you find after you build the car. Information about recommended CG location, and its influence, will be posted on the Event Website.

**Wheel Base / Width Ratio:** It is recommended that the wheel base to width ratio be greater than 1.5.

## **Appendix K. Multi-Occupant Vehicle Practicality Judging**

The following is an example list of areas that may be considered for the determination of the practicality scoring for the solar car.

This list is not intended to be comprehensive, additional items may be considered, and not all items may be included in the final scoring.

Driver and Occupant Amenities

Quality of Features

Infotainment System

Phone Connectivity

Ease of Operation

Internal and External Styling

Fit & Finish

Watertight Cabin

Visibility

Seats

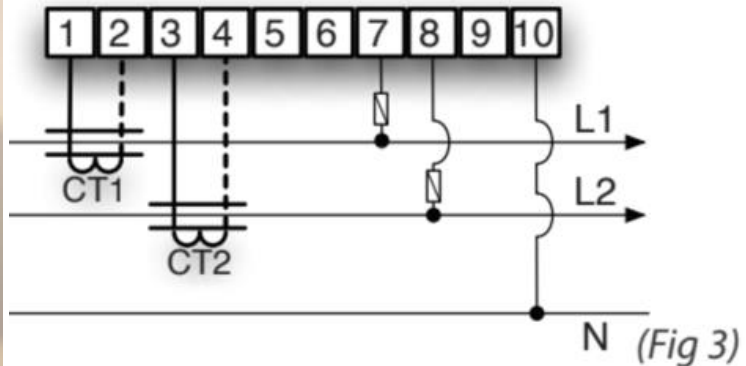
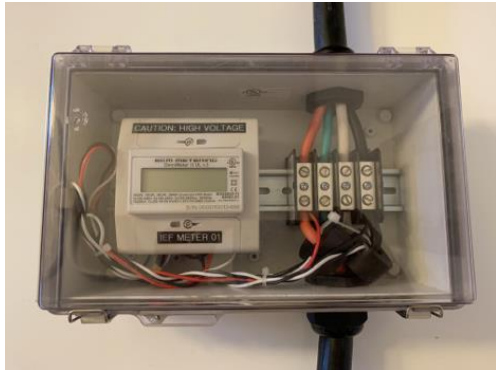
Doors

Cargo Space

Spare Tire Kit

## Appendix L. Onboard MOV Energy Meter Overview

- This onboard energy meter will be provided to MOV teams by IEF
- The meter must be installed in the solar car during Scrutineering
- EKM Omnimeter Pulse v.4 kWh meter provides revenue grade metering accuracy
- Flexible 120-240 Vac input voltage at up to 40A current
- Watertight enclosure with sealed cable glands
- ~\$500 estimated cost for this charge meter solution

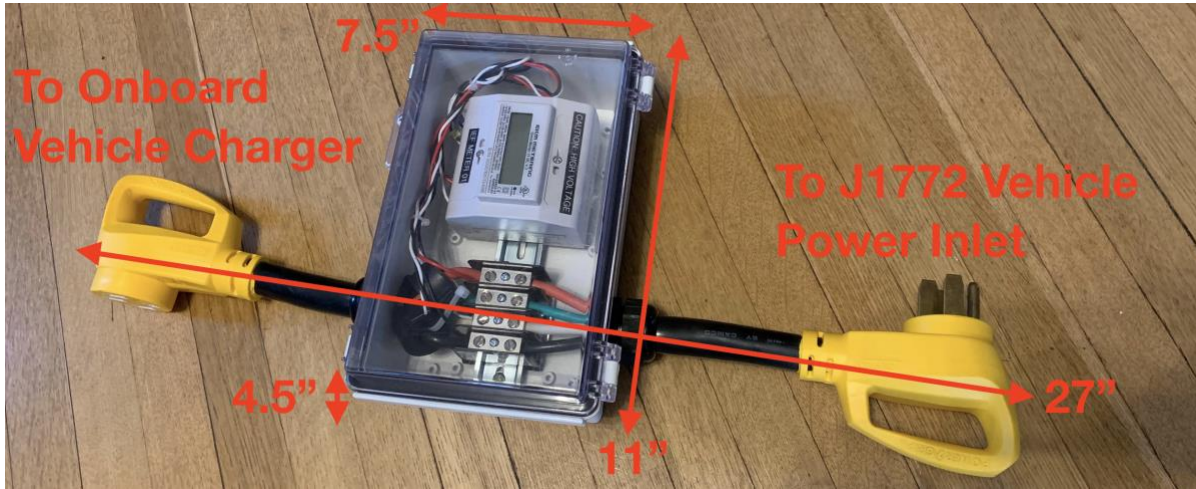


### Meter BOM (for Reference)

Item	QTY	Unit Cost	Total Cost
EKM Omnimeter Pulse v.4 – Universal Smart Meter	1	\$ 260.00	\$ 260.00
EKM Split-core CT, 200A Current Transformer	2	\$ 45.00	\$ 90.00
EKM Watertight Enclosure with Hinged and Latching Lid (6.7" x 10.63" x 4.33")	1	\$ 80.00	\$ 80.00
Camco 55215 18" PowerGrip Extender - 50 AMP	2	\$ 19.95	\$ 39.90
Marathon Special Products 1414300 Splicer Block, 4-P, 115A, Line: 2AWG-14AWG	1	\$ 18.08	\$ 18.08
Waterproof Cable Gland (2pc Set)	1	\$ 10.05	\$ 10.05
<b>Total</b>			<b>\$ 498.03</b>

# Meter Packaging

The kWh hour meter is watertight, weighs 6lb, and has enclosure dimensions of 11" L x 7.5" W x 4.5" H with a connector to connector length of 27".



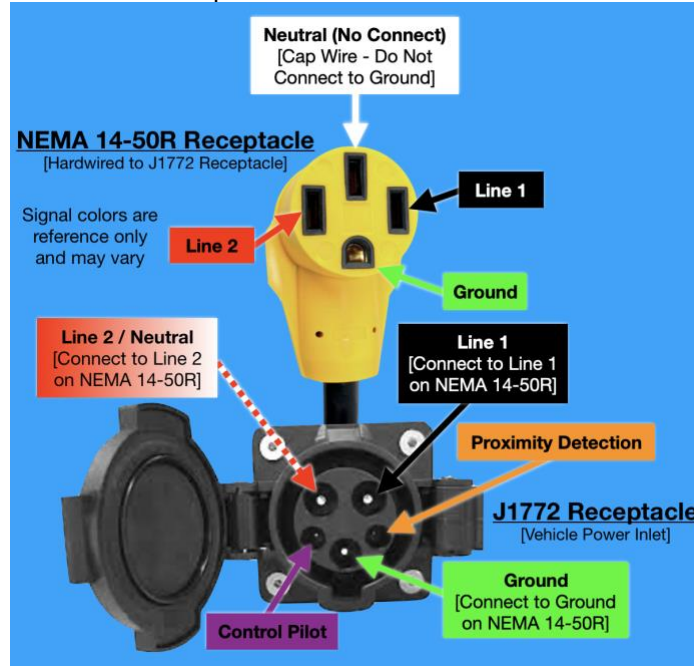
# Solar Car Integration

MOV solar cars must feature an inline NEMA 14-50 connection between the J1772 Vehicle Power Inlet and the Onboard Vehicle Charger. When not at an ASC/FSGP Event, the NEMA 14-50 connectors will be directly connected as shown below.



When the team comes to an ASC/FSGP Event, they will disconnect the NEMA 14-50 connectors and plug them into the kWh Charge Meter as shown below. The NEMA connectors will be sealed together for the duration of the Event so the meter can't be bypassed.

The J1772 receptacle and NEMA 14-50 receptacle should be wired as follows to match the meter:



## Appendix M. Revision Table

Rev	Description	Date
A	<ul style="list-style-type: none"> <li>7: updated "Grandfathered" class to "demonstration" class</li> <li>8.1.H: no water spraying arrays</li> <li>8.2: capacity-based battery size instead of weight</li> <li>8.3.A.9: Updated safe state wording</li> <li>8.4.D: updated battery ventilation requirements</li> <li>10.9.F: addition of acceleration test (proxy for hillclimb)</li> <li>Clarifications to occupant cell definition</li> </ul>	2024-10-04
B	<ul style="list-style-type: none"> <li>Corrected broken image on page 40 in 10.3.B.4</li> <li>Fixed Appendix F heading on the wrong page</li> </ul>	2024-10-29
C	<ul style="list-style-type: none"> <li>4.1.A.2: Gave discretion for inspectors to grade reports for teams who have not yet paid the initial entry fee</li> <li>4.2.B: Clarified language and linked to relevant appendices</li> <li>4.3.A.5: Added official due date</li> <li>5.2.D: Changed from "mass and cost" to "capacity" from manufacturer's data</li> <li>5.3: Clarification added for color grading of reports</li> <li>8.2.C.2: Changed from "may" to "must"</li> <li>8.4.D: Forced air ventilation only applies to the enclosure(s) containing the main battery</li> <li>8.6.A.4: Added official interpretation from ASC 2024 clarifying the required position of the safe state switches in the battery circuit</li> <li>Updated 9.5.B to clarify all forward vision test points</li> <li>Clarified that 10.3.B.3 only applies to the yaw angle</li> </ul>	2025-03-27

Rev	Description	Date
	<ul style="list-style-type: none"><li data-bbox="386 197 1052 289">• Added 10.6.C.4: Parking brake must not disengage without being commanded to, text about electrically actuated parking brakes.</li><li data-bbox="386 289 716 321">• 12.2: re-worded/clarified</li><li data-bbox="386 321 1029 352">• 12.9.D: Added reg about use of track transponders</li></ul>	